

# Table of Contents

<b>1. Introduction.....</b>	<b>5</b>
1.1. Box Content .....	6
1.1.1. Original Packaging and Servicing the 5big Backup Server.....	6
1.2. Minimum Network Requirements .....	7
1.2.1. Ethernet Connection .....	7
1.2.2. Wireless Support .....	7
1.3. Minimum Workstation Operating System Requirements .....	8
1.4. Views of the 5big Backup Server.....	9
1.4.1. Front View .....	9
1.4.2. Rear View .....	9
1.4.3. 5big Backup Server Numbered Slots and Disk Trays .....	10
1.5. Windows Home Server and the 5big Enclosure Disks .....	11
1.6. Ethernet Cable.....	11
<b>2. Setting Up Your LaCie 5big Backup Server .....</b>	<b>12</b>
2.1. Turning On the 5big Backup Server.....	13
2.2. Connecting the Ethernet Cable .....	14
2.3. Install the 5big Backup Server Connector CD .....	15
2.4. Complete the 5big Backup Server Setup .....	16
<b>3. 5big Backup Server Configuration.....</b>	<b>18</b>
3.1. User Accounts .....	19
3.2. Shared Folders .....	20
3.2.1. Folder and File Duplication .....	20
3.2.1.1. Folder Duplication with a single disk in the enclosure.....	21
3.3. Computer Backups .....	22
3.4. Server Storage.....	23
3.4.1. Backup Drives Larger Than 2TB .....	24
3.4.2. Disks Larger Than 2TB and the Windows Home Server Storage Hard Drives .....	24
3.5. Windows Home Server Settings .....	25
3.5.1. Network Healthy/Network Critical and Important Updates.....	26
<b>4. LaCie Dashboard .....</b>	<b>28</b>
4.1. Printer Management.....	28
4.2. Multimedia Server .....	29
4.3. Hardware Management.....	30
4.4. Internet Settings .....	31
4.5. Disk Information .....	32
<b>5. Mac Support.....</b>	<b>33</b>
5.1. Mac Clients on the 5big Backup Server.....	33
5.1.1. Accessing Shared Folders (Volumes).....	33
5.1.2. Time Machine .....	35
5.1.3. Managing and Monitoring Mac Clients .....	36
<b>6. Removing and Installing New Disks .....</b>	<b>38</b>
6.1. Disk Installation .....	38

6.1.1. Fastening a non-LaCie Hard Disk to a 5big Enclosure Drive Tray.....	40
6.2. Adding a new disk to the 5big Backup Server storage .....	42
<b>7. Recovery .....</b>	<b>43</b>
7.1. Recovery: 5big Backup Server .....	43
7.1.1. Server Recovery USB 2.0 Flash Drive.....	43
7.1.2. 5big Backup Server Recovery.....	46
7.2. Recovery: Workstations on the 5big Backup Server Network .....	48
7.2.1. Workstation Drivers and File Recovery .....	48
7.2.2. PC Recovery USB 2.0 Flash Drive (Optional).....	50
7.2.3. PC Recovery (Windows Workstations Only) .....	52
<b>8. LED Indicators .....</b>	<b>59</b>
<b>9. Troubleshooting .....</b>	<b>60</b>
<b>10. Contacting Customer Support .....</b>	<b>63</b>
10.1. LaCie Technical Support Contacts.....	64
<b>11. Warranty Information .....</b>	<b>65</b>

## Copyrights

Copyright © 2011 LaCie. All rights reserved. No part of this publication may be reproduced, stored in a retrieval system, or transmitted in any form or by any means, electronic, mechanical, photocopying, recording or otherwise, without the prior written consent of LaCie.

## Trademarks

Apple, Mac, and Macintosh are registered trademarks of Apple Computer, Inc. Microsoft, Windows 98, Windows 98 SE, Windows 2000, Windows Millennium Edition, Windows XP, Windows Vista, and Windows 7 are registered trademarks of Microsoft Corporation. Other trademarks mentioned in this manual are the property of their respective owners.

## Changes

The material in this document is for information only and subject to change without notice. While reasonable efforts have been made in the preparation of this document to assure its accuracy, LaCie assumes no liability resulting from errors or omissions in this document, or from the use of the information contained herein. LaCie reserves the right to make changes or revisions in the product design or the product manual without reservation and without obligation to notify any person of such revisions and changes.

## Canada Compliance Statement

This Class A digital apparatus meets all requirements of the Canadian Interference-Causing Equipment Regulations.

## ROHS Compliance

This product is ROHS compliant (European Directive 2002/95/EC on the Restriction of Hazardous Substances).

## FCC Statement

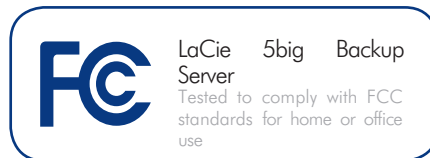

This device complies with Part 15 of the FCC Rules. Operation is subject to the following conditions:

- ◆ The devices may not cause harmful interference
- ◆ The devices must accept any interference received, including interference that may cause undesired operation.

NOTE: This equipment has been tested and found to comply with the limits for a Class B digital device, pursuant to Part 15 of the FCC Rules. These limits are designed to provide reasonable protection against harmful interference in a residential installation. This equipment generates, uses and can radiate radio frequency energy and, if not installed and used in accordance with the instructions, may cause harmful interference to radio communications. However, there is no guarantee that interference will not occur in a particular installation. If this equipment does cause harmful interference to radio or television reception, which can be determined by turning the equipment off and on, the user is encouraged to try and correct the interference by one or more of the following measures:

- ◆ Reorient or relocate the receiving antenna.
- ◆ Increase the separation between the equipment and receiver.
- ◆ Connect the equipment into an outlet on a circuit different from that to which the receiver is connected.
- ◆ Consult the dealer or an experienced radio/TV technician for help.

Modifications to this product not authorized by LaCie could void the FCC & Industry Canada regulations and negate your authority to operate the product.

## CE Manufacturer's Declaration for CE Certification

We, LaCie, solemnly declare that this product conforms to the following European directives: 2004/108/EC (EMC), and 2006/95/EC (Safety)



This symbol on the product or on its packaging indicates that this product must not be disposed of with your other household waste. Instead, it is your responsibility to dispose of your waste equipment by handing it over to a designed collection point for the recycling of waste electrical and electronic equipment. The separate collection and recycling of your waste equipment at the time of disposal will help to conserve natural resources and ensure that it is recycled in a manner that protects human health and the environment. For more information about where you can drop off your waste equipment for recycling, please contact your local city office, your household waste disposal service, or the shop where you purchased the product.

---

**CAUTION:** A shielded-type power cord is required in order to meet FCC emission limits and also to prevent interference to the nearby radio and television reception. It is essential that only the supplied power cord be used.

---

## Health and Safety Precautions

- ◆ Only qualified persons are authorized to carry out maintenance on this device.
- ◆ Read this User Manual carefully and follow the correct procedure when setting up the device.
- ◆ Do not open your LaCie 5big Backup Server or attempt to disassemble or modify it. Never insert any metallic object into the drive to avoid any risk of electrical shock, fire, short-circuiting, or dangerous emissions. Your LaCie 5big Backup Server contains no user-serviceable parts. If it appears to be malfunctioning, have it inspected by a qualified LaCie Technical Support representative.
- ◆ Never expose your device to rain, or use it near water, or in damp or wet conditions. Never place objects containing liquids on the LaCie 5big Backup Server, as they may spill into its openings. Doing so increases the risk of electrical shock, short-circuiting, fire or personal injury.
- ◆ Power requirements 100-240 V~, 1.44 A, 50-60 Hz, (supply voltage fluctuations not exceeding  $\pm 10\%$  of the nominal and transient over-voltages according to over-voltage category II).

## General Use Precautions

- ◆ Do not expose your device to temperatures outside the range of 5° C to 35° C (41° F to 95° F); or to operational humidity beyond 5-80%, non-condensing, or non-operating humidity beyond 10-90%, non-condensing. Doing so may damage it or disfigure its casing. Avoid placing your device near a source of heat or exposing it to sunlight (even through a window). Inversely, placing your device in an environment that is too cold or humid may damage the unit.
- ◆ Always unplug the device from the electrical outlet if there is a risk of lightning or if it will be unused for an extended period of time. Otherwise, there is an increased risk of electrical

shock, short-circuiting or fire.

- ◆ Use only the power supply shipped with the device.
- ◆ Do not use the device near other electrical appliances such as televisions or radios. Doing so may cause interference which will adversely affect the operation of the other products.
- ◆ Do not place the device near sources of magnetic interference, such as computer displays, televisions or speakers. Magnetic interference can affect the operation and stability of your device.
- ◆ Never use excessive force on your device. If you detect a problem, see the Troubleshooting section in this manual.

---

**IMPORTANT INFO:** Any loss, corruption or destruction of data while using a LaCie drive is the sole responsibility of the user, and under no circumstances will LaCie be held liable for the recovery or restoration of this data. To help prevent the loss of your data, LaCie highly recommends that you keep **TWO** copies of your data; one copy on your external hard disk, for instance, and a second copy either on your internal hard disk, another external hard disk or some other form of removable storage media. LaCie offers a complete line of CD and DVD drives. If you would like more information on backup, please refer to our website.

---

**IMPORTANT INFO:** 1GB = 1,000,000,000 bytes. 1TB = 1,000,000,000,000 bytes. Once formatted, the actual available storage capacity varies depending on operating environment (typically 10-15% less).

---

---

**TECHNICAL INFORMATION:** The 5big Backup Server must receive its IP address from a DHCP server.

---

# 1. Introduction

Congratulations on your purchase of a LaCie 5big Backup Server. Offering expansive file sharing and backup features, the 5big Backup Server is designed to satisfy the daily needs of small offices that are looking for an easy solution to network storage. Powered by Microsoft® Windows Home Server®, the 5big Backup Server provides a familiar interface while managing your data, software, backups, and more. There are many additional benefits, such as remote access to your files from anywhere in the world and the fun of sharing digital media among all users and digital media adapters.

## Superior Design

The 5big Backup Server's advanced metal casing and thermoregulator fan ensure long-lasting reliability and quiet operation. The glowing blue button adds more than character—one push will turn your 5big Backup Server on. Sturdy disk trays are easy to remove for maintenance and lock securely in place for safety.

## Folder Duplication

The 5big Backup Server allows for instant control of your files via folder duplication. Rather than taking up valuable disk space with unnecessary duplication, you get to choose which files should be mirrored at the folder level. Since your critical files are copied to separate disks, you can rest assured that your data is secure in the unlikely event of disk failure.

## Easy Setup & Access

Installing the Windows Home Server Connector is a snap, leaving you ready to share folders and begin backups of all the computers on your network in a very short time. Networking has never been so easy!



### Quick Links

#### Click a topic:

- ◆ [Setting Up Your LaCie 5big Backup Server](#)
- ◆ [5big Backup Server Configuration](#)
- ◆ [Troubleshooting](#)

## 1.1. Box Content

Your LaCie 5big Backup Server package contains the items listed below:

1. LaCie 5big Backup Server
2. Cat 5E Ethernet cable
3. Power supply
4. Connector Agent and Utilities Disk (applications and documentation)
5. PC Recovery CD
6. Server Recovery DVD
7. Quick Start Guide
8. Drive lock tool
9. Packet of disk tray screws (5big Backup Server single disk only)

### 1.1.1. Original Packaging and Servicing the 5big Backup Server

Please save the 5big Backup Server packaging.

- ◆ In the event that it should require repair or service, the 5big Backup Server must be returned in its original packaging.
- ◆ When sending the 5big Backup Server, make certain to return all items in the original packaging.
- ◆ If you purchased a single disk 5big Backup Server, please remove the non-LaCie disks before sending the server for service.
- ◆ Before returning the 5big Backup Server, please backup all data stored on its disk drives. LaCie cannot guarantee that your data will be preserved during a repair.



## 1.2. Minimum Network Requirements

### 1.2.1. Ethernet Connection

To successfully use the 5big Backup Server, your home network must meet the following requirements:

Requirement	Minimum
Server connection	100 Mbps wired connection. LaCie highly recommends a 1 Gb/s wired connection for better performance.
Workstations	One or more computers that are running a supported operating system, with either a wired or a wireless network connection.
Internet	Broadband connection for software updates
Router/firewall device	An external Internet broadband router/firewall device with 100 Mbps wired Ethernet connection.  The 5big Backup Server assumes that your network devices receive their IP address from a DHCP server.

**IMPORTANT INFO:** Find a suitable place to put your 5big Backup Server before you run Windows Home Server Setup. The location you choose must have an available, wired network connection either to your broadband router or to a switch that is connected to your broadband router.

### 1.2.2. Wireless Support

- ◆ The 5big Backup Server joins your network via a wired, Ethernet cable. Please note that the 5big Backup Server does not support a wireless (Wi-Fi) connection to your network
- ◆ Wireless devices and workstations that have joined the network may access the 5big Backup Server.

**IMPORTANT INFO:** The 5big Backup Server's performance can be affected by such external forces as network activity, hardware, distance and setup.

**IMPORTANT INFO:** For optimal performance, use a Gigabit Ethernet router and Gigabit Ethernet on your host computer.

**TECHNICAL INFORMATION:** The 5big Backup Server must receive its IP address from a DHCP server.

## 1.3. Minimum Workstation Operating System Requirements

The most recent versions of:

- ◆ Windows® XP
- ◆ Windows® Vista
- ◆ Windows® 7

The 5big Backup Server may be accessed by workstations running the latest versions of Mac® OS X:

- ◆ 10.5
- ◆ 10.6

The 5big Backup Server may be used for Time Machine® backups. See [5. Mac Support](#).

---

---

**TECHNICAL NOTE:** Please update your 5big Backup Server software whenever a new version is available. Regular updates will enable support for the most recent workstation operating systems.

---

---



## 1.4. Views of the 5big Backup Server

### 1.4.1. Front View

#### On/Off Button with Status LED (Fig. 01)

1. On/Off power switch - The blue button on the front of the 5big Backup Server turns the unit on or off. The LED remains lit to show that the server is on.

---

**IMPORTANT INFO:** Pushing the front LED button while the 5big Backup Server is running will shut the system off. This is true even if the 5big Backup Server is currently in use. Please keep the unit in a location that will prevent accidentally pushing the front LED button while the 5big Backup Server is being accessed by users. LaCie recommends shutting down the 5big Backup Server in a normal fashion via the Console.

---

### 1.4.2. Rear View

(Fig. 02)

2. Ethernet port
3. Stereo audio out
4. USB 2.0 expansion ports (4)
5. eSATA expansion port
6. Power input connection
7. System recovery button
8. Drive tray lock
9. Drive tray handle
10. Drive LED

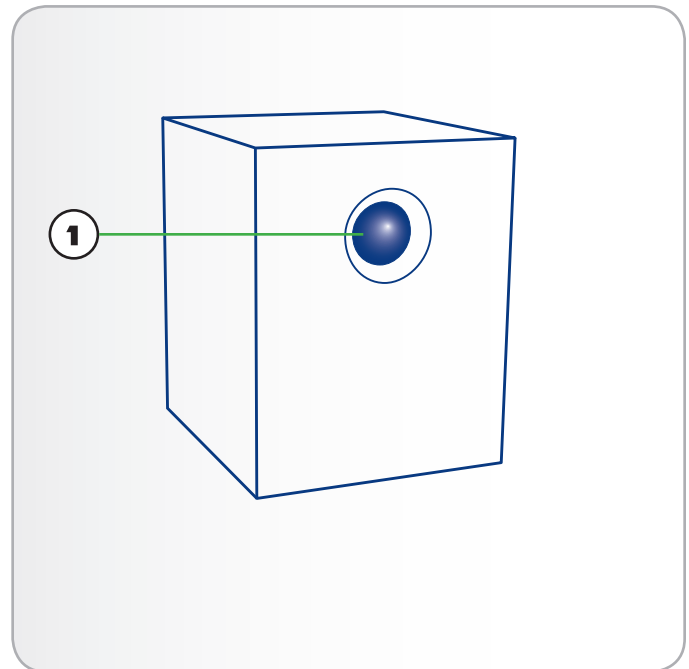

Fig. 01

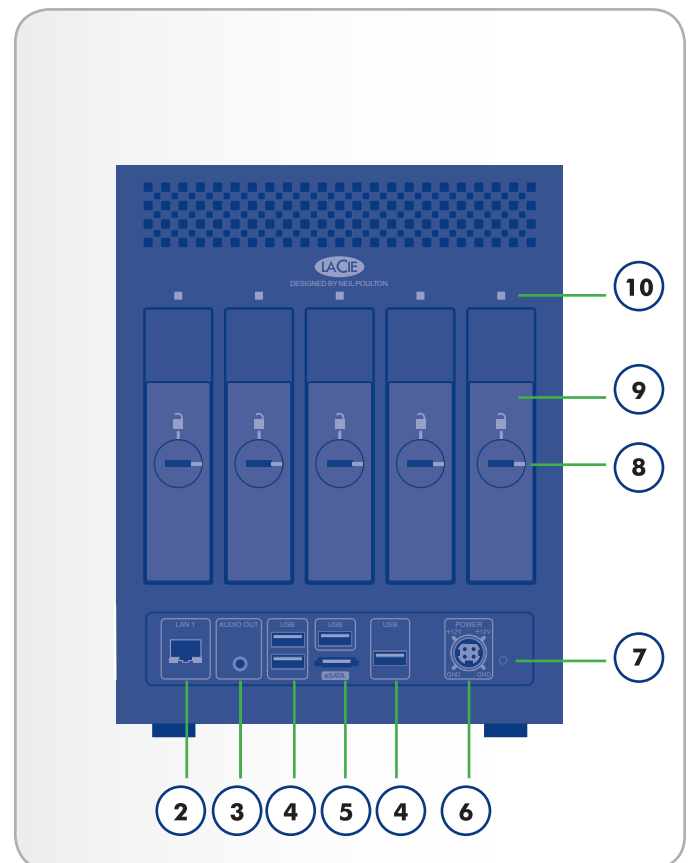

Fig. 02

### 1.4.3. 5big Backup Server Numbered Slots and Disk Trays

(Fig. 03)

For convenience when adding or removing disks, the 5big Backup Server drive slots and trays have matching numbers.



Fig. 03

## 1.5. Windows Home Server and the 5big Enclosure Disks

The 5big Backup Server has five slots to insert hard disk drives (see 6.1. [Disk Installation](#) for instructions on how to insert new or replacement disks). [Fig. 04](#) shows how the drives are labeled, from left to right:

**Disk 1** contains the Windows Home Server operating system. While other drives may be removed during use, the 5big Backup Server requires this disk for proper operation and management of the system.

**Disks 2 - 5** may be added to the Windows Home Server pool of Storage Hard Drives or used to backup data on the system. See 3.4. [Server Storage](#) to learn how to add or remove drives from the pool of Storage Hard Drives.

Four USB ports ([Fig. 04](#), A) and one eSATA port ([Fig. 04](#), B), are also available to expand storage on the 5big Backup Server. You may add external disks to the Windows Home Server pool of Storage Hard Drives or use them as backup for data on the system.

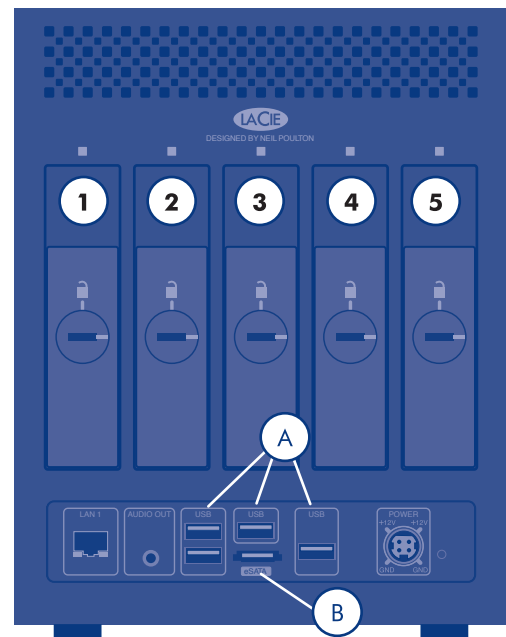

Fig. 04

---

**IMPORTANT INFO:** Use USB 2.0 devices with the 5big Backup Server USB 2.0 ports (i.e. external hard drives or printers). USB 1.1 devices can cause poor performance and unpredictable results.

---

## 1.6. Ethernet Cable

### Gigabit Ethernet Cables and Connectors

Your LaCie 5big Backup Server is shipped with an Ethernet cable ([Fig. 05 - Ethernet Cable Ends](#)) that is compatible with transfer rates up to 1000 Mb/s, or 1 Gb/s. Often referred to as “Gigabit Ethernet” or “Gig-E”, this level of Ethernet connection is superior to older, 100 Mb/s connections.

---

**TECHNICAL NOTE:** LaCie recommends Cat 5E or Cat 6 cables. Both support Gigabit Ethernet.

---

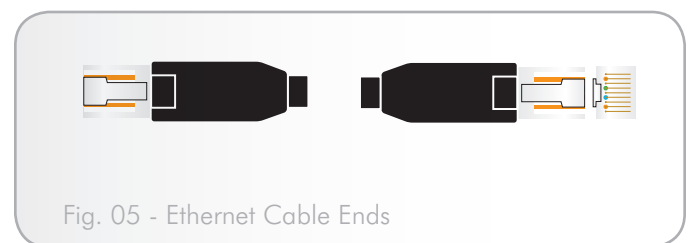

Fig. 05 - Ethernet Cable Ends

## 2. Setting Up Your LaCie 5big Backup Server

Follow these steps to power on and prepare the LaCie 5big Backup Server for use on the network.

**Step 1** – 2.1. *Turning On the 5big Backup Server*

**Step 2** – 2.3. *Install the 5big Backup Server Connector CD*

**Step 3** – 2.4. *Complete the 5big Backup Server Setup*

---

**IMPORTANT INFO:** LaCie recommends using the 5big Backup Server in a small network environment with a maximum of 10 Windows workstations. Additional Mac stations may also access data on the 5big Backup Server.

---

---

**IMPORTANT INFO:** Please consider your storage capacity requirements before connecting workstations to the 5big Backup Server. For example, a 5big Backup Server with a single disk may have insufficient storage to support backups from ten workstations.

---

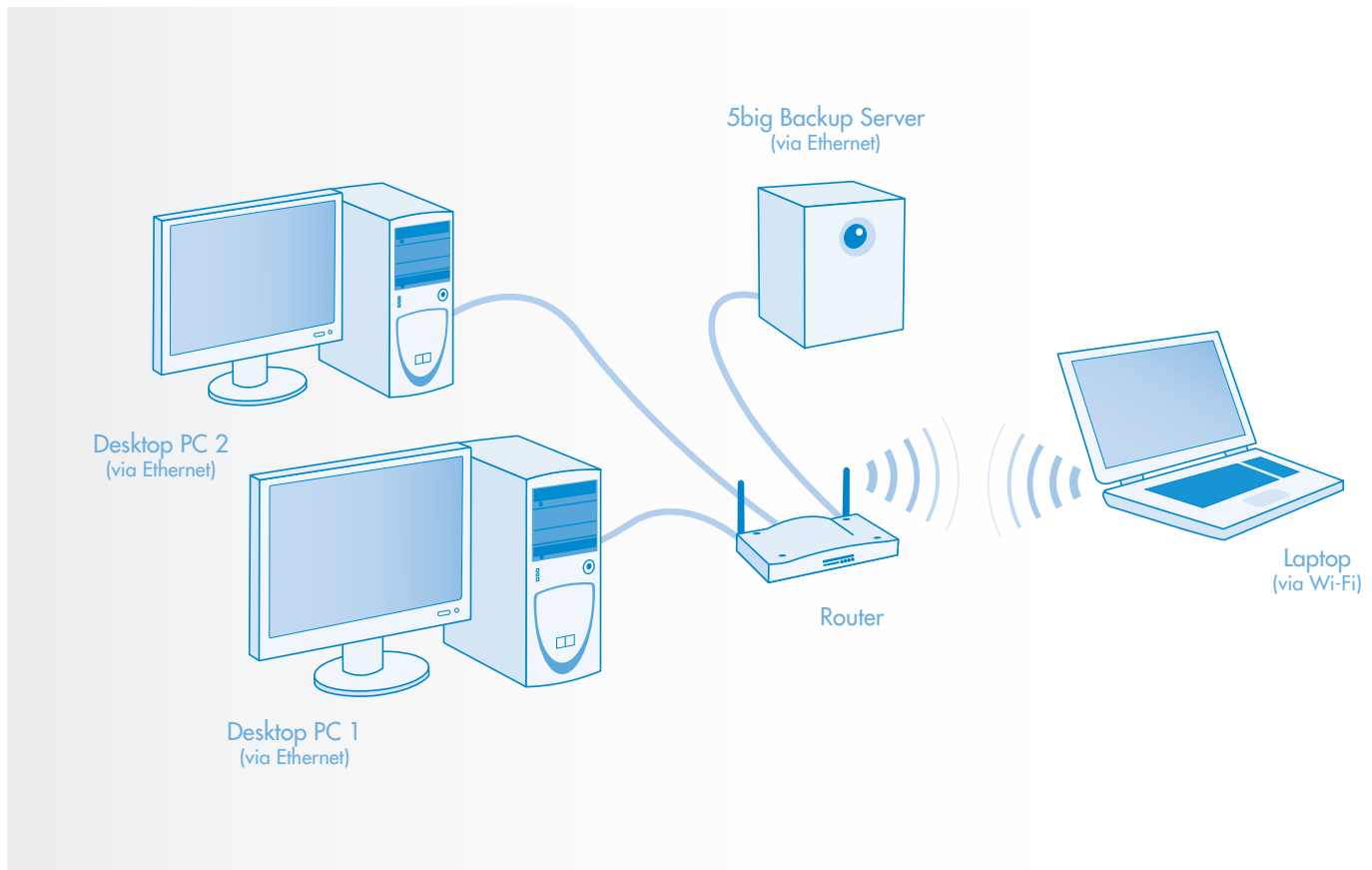

## 2.1. Turning On the 5big Backup Server

The power supply kit is composed of two cables: one cable (A) connects to the LaCie 5big Backup Server; and the other cable (B) connects to a power outlet, such as a wall outlet or a surge protector (Fig. 06).

1. Connect Cable A to the 5big Backup Server.
2. Connect Cable B to the power supply brick (C).
3. Connect Cable B to a surge protector or wall outlet.
4. Turn on the server by pushing the button on the face of the 5big Backup Server. (See [1.4.1. Front View](#))
5. The 5big Backup Server is powered and ready for use when the front LED stops blinking.

---

**IMPORTANT INFO:** The 5big Backup Server may take a few minutes to boot the first time it is turned on.

---

**CAUTION:** Only use the AC adapter supplied with your specific LaCie device. Since each product is unique, do not substitute a power supply from another LaCie device or another manufacturer for the LaCie 5big Backup Server.

Please note that the AC adapter provided with your LaCie device includes connectors for electrical outlets in multiple regions. Thanks to its 100-240 Volt power supply, you may use your device in a foreign country. However, LaCie accepts no responsibility for any damage to the drive resulting from the use of an inappropriate adapter. Further, your warranty will be void if you:

- ◆ Use a power cable, power supply, or power adapter other than one that has been authorized by LaCie.
  - ◆ Do not remove your AC adapter when transporting your LaCie device. Neglecting to do so may damage your 5big Backup Server.
- 

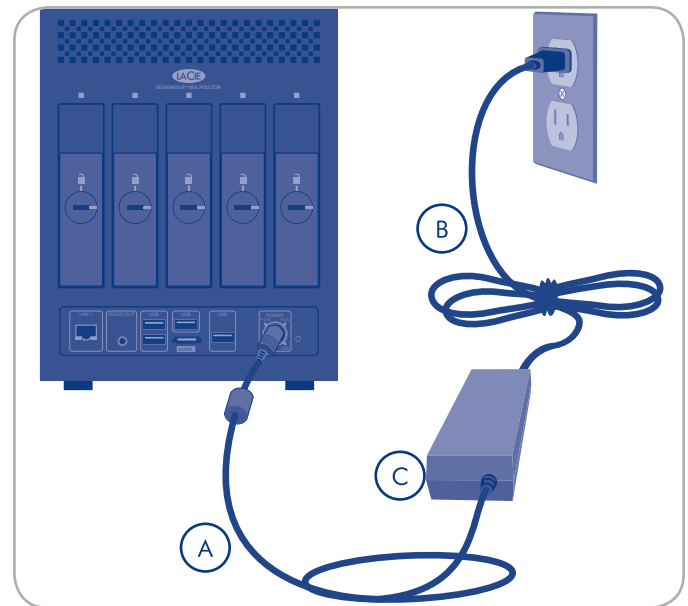

Fig. 06

## 2.2. Connecting the Ethernet Cable

The 5big Backup Server is accessible when attached to your network ([Fig. 07](#)). The USB 2.0 and eSATA ports are for expansion only and should not be used to connect the 5big Backup Server to a computer.

1. Connect the Ethernet cable to the Ethernet port on the back of the LaCie 5big Backup Server ([1.4.2. Rear View](#)).
2. Connect the other end of the Ethernet cable into an available Ethernet port on your router.
3. Turn the server on if it is off. See [2.1. Turning On the 5big Backup Server](#).

---

**TECHNICAL INFORMATION:** The 5big Backup Server must receive its IP address from a DHCP server.

---

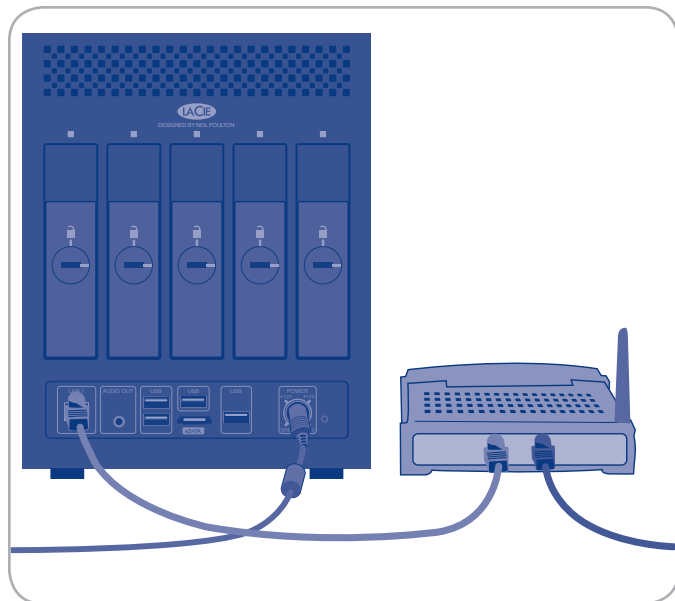

Fig. 07

## 2.3. Install the 5big Backup Server Connector CD

The Connector software does the following:

- ◆ Connects your workstations to the 5big Backup Server.
- ◆ Automatically backs up your Windows workstations nightly.
- ◆ Monitors the health of connected workstations.
- ◆ Enables you to configure and remotely administer the 5big Backup Server from any connected workstation.
- ◆ Initializes your 5big Backup Server the first time it is run.

---

**IMPORTANT INFO:** Folder Duplication will not be enabled by default when the Connector is run on a 5big Backup Server with only one disk. See [3.2.1. Folder and File Duplication](#) for further information.

---



---

**IMPORTANT INFO:** The Connector must be run from a Windows workstation. For details on connecting a computer running the Mac OS, see [5. Mac Support](#).

---

1. Insert the 5big Backup Server Connector CD into a computer that is connected to your network. From the list of items ([Fig. 08](#)), choose **Applications**.
2. Click **Home Server Connector** ([Fig. 09](#)).
3. Click **Next>** on the Welcome screen to begin the installation.
4. Complete the wizard to connect your computer to the 5big Backup Server.
5. The Setup will launch directly after the Wizard is finished only when the Connector is run for the first time. See [2.4. Complete the 5big Backup Server Setup](#).

Once the Setup is complete, run the Connector CD on all of the network computers to connect them to the 5big Backup Server. Run the wizard on one computer at a time.

---

**NOTE:** If you do not have your Connector CD, you can install the Connector software from the shared folder **Software** on the 5big Backup Server. The **Software** folder should be available on your network after the Setup has been completed for the first time. You may also find the Connector installer at <http://5bigbackup:55000>. The address is for your local network with "5bigbackup" referring to the name of your LaCie 5big Backup Server. Please replace it in the address if you have changed the default name.

---



Fig. 08

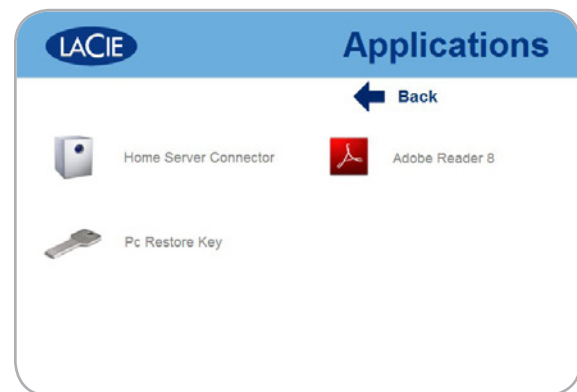

Fig. 09



Fig. 10

## 2.4. Complete the 5big Backup Server Setup

Windows Home Server Setup runs only once, from the first computer you install the Connector CD. You must complete the Setup successfully to ensure that the 5big Backup Server functions properly.

### To complete the Setup:

1. On the **Welcome** screen, click the **Next** arrow.
2. A window will ask if you want to wake up the workstation for daily backups. Select **Yes** or **No** then the **Next** arrow (Fig. 11).
3. On the **Name your home server page**, you may type a name for your 5big Backup Server or keep the default, 5BIGBACKUP. Click the **Next** arrow (Fig. 12).

The name you choose can contain the following:

- ◆ 15 characters maximum, with no spaces
  - ◆ Letters (at least one), numbers, and hyphens
4. On the **Type a password for Windows Home Server** page, type a password, the password confirmation, and a password hint, and then click the **Next** arrow. (Fig. 13)

This is the password that you use to manage your 5big Backup Server from the Windows Home Server Console. The password is case-sensitive, and it must be strong. A strong password must be at least seven characters long, and it must contain at least three of the following four character categories:

- ◆ Uppercase characters
- ◆ Lowercase characters
- ◆ Numbers
- ◆ Symbols (such as !, @, #, etc.)

---

**IMPORTANT INFO:** You cannot change settings in the Console without the Administrator password. LaCie highly recommends that you note your password in a safe place. As well, the password hint offered by the Setup (Fig. 13) can provide assistance should you forget while using the 5big Backup Server. Please keep in mind that the password hint can be seen by anybody who clicks on the link to display it. If the Administrator password is forgotten and the password hint does not help to recover it, you will have to reset your server.

---

continued on the next page>>

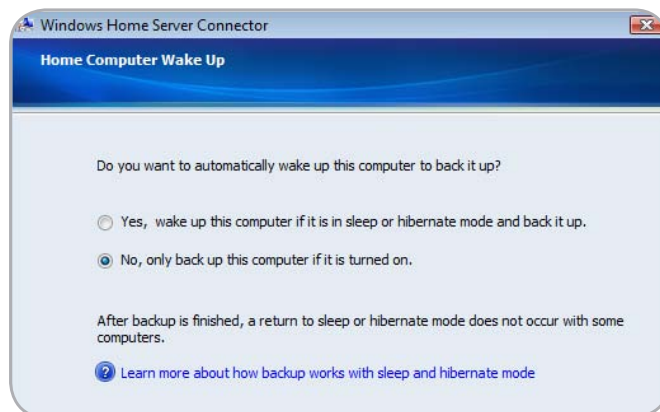

Fig. 11

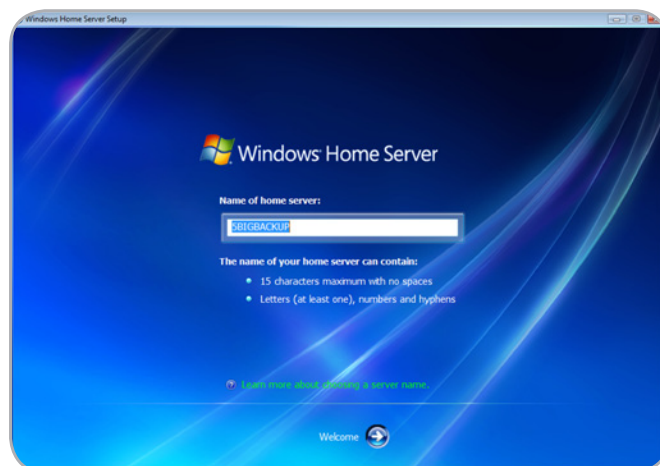

Fig. 12

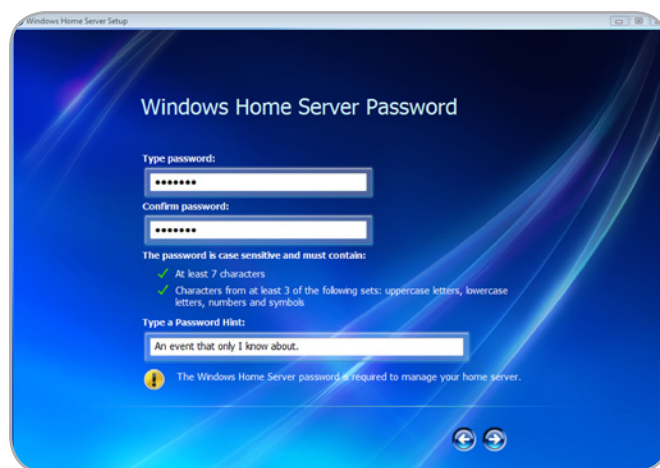

Fig. 13



5. Choose how to receive important updates for the 5big Backup Server. **Use recommended settings** is an ideal choice since your 5big Backup Server will automatically check for updates and install them for you (Fig. 14). Click the **Next** arrow.
6. On the final **Setup** page, click **Start** to begin configuring your 5big Backup Server (Fig. 16).

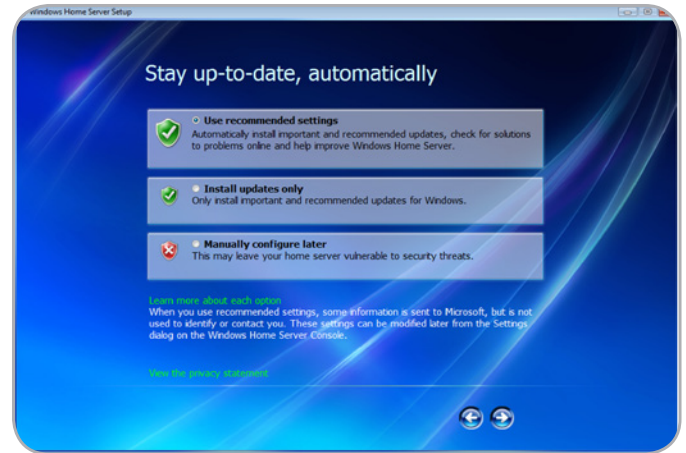

Fig. 14

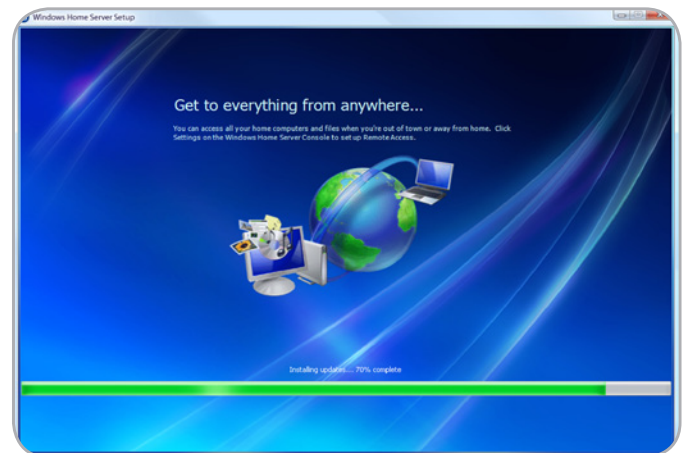

Fig. 15

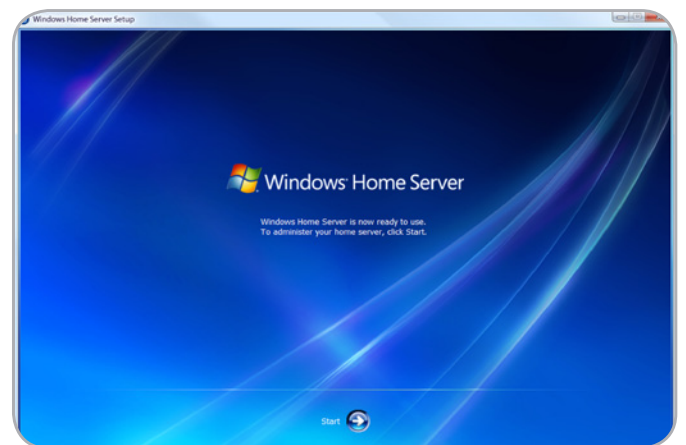

Fig. 16

## 3. 5big Backup Server Configuration

### Starting the Console

The Windows Home Server Console will start after the Connector has completed the software installation. To launch the Console in the future, you may click **Start>Programs>Windows Home Server Console**. You will also find the Console icon in the tray on the lower right of your screen (Fig. 17). Double-click on the icon to launch the program or right-click on it for additional options.

The Connector installation will also add the shortcut **Shared Folders on Server** for easy access to files stored on the 5big Backup Server.

---

**IMPORTANT INFO:** The Console may be run on one computer at a time and is only compatible with Windows workstations. Mac computers may access data on the 5big Backup Server (see [5. Mac Support](#)).

---

### Console Tasks

The following are tasks that you can configure as soon as the 5big Backup Server is set up and your workstations are connected:

- ◆ User accounts
- ◆ Shared folders
- ◆ Computer backups
- ◆ Server storage
- ◆ 5big Backup Server Settings

To learn more about configuring the 5big Backup Server, click **Help** on the Console.

---

**IMPORTANT INFO:** While one hopes never to experience a problem, it is critical to prepare for all eventualities. Therefore, soon after setting up your network server, LaCie highly recommends that you create a system recovery USB 2.0 flash drive (see [7. Recovery](#)).

---

---

**MANUAL NOTE:** For more information on the LaCie Dashboard, please see [4. LaCie Dashboard](#).

---

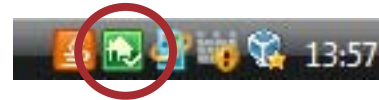

Fig. 17

### 3.1. User Accounts

After the Setup is complete and the software has been installed on all of the workstations, you are ready to add user accounts for the computers that will access the 5big Backup Server. User accounts are required in order to access the shared folders on the 5big Backup Server and to configure regular backups.

#### To add a user account

1. From a workstation, right-click the Console tray icon, and then click **Windows Home Server Console**.
2. Type the password, and then click the **Next** arrow.
3. Click the **User Accounts** tab (Fig. 18).
4. Click **Add**, and then complete the **Add User Account Wizard**.
5. Repeat for each user account that you want to add.

---

**IMPORTANT NOTE:** When creating user accounts on the 5big Backup Server, try to match the logon names and passwords of the existing user accounts on the workstations. This makes it easier to access shared folders on the 5big Backup Server. If the user accounts and passwords do not match, users will be prompted for a logon and a password when attempting to access shared folders.

---

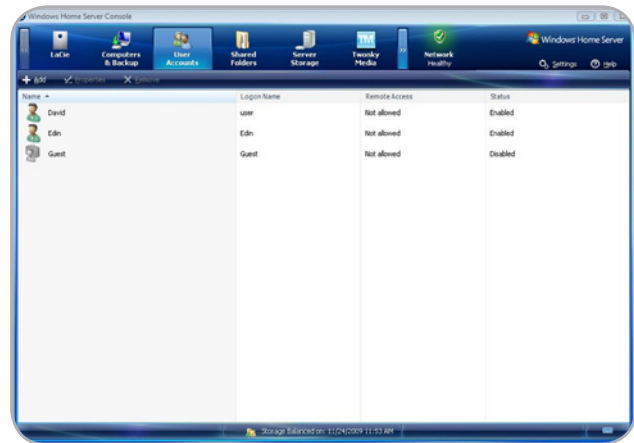

Fig. 18

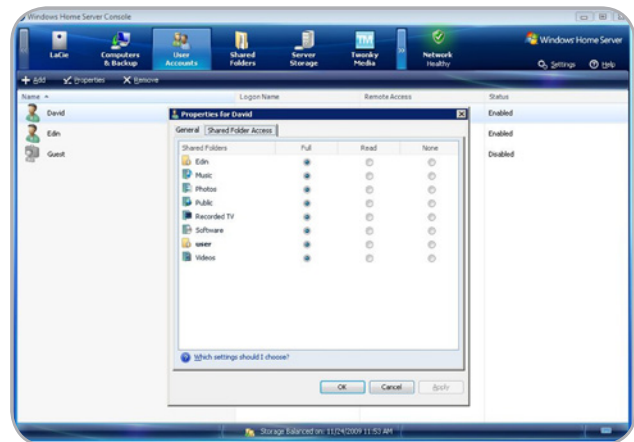

Fig. 19

## 3.2. Shared Folders

Shared folders are places for you to organize and store files on the 5big Backup Server so that you can share them with other workstations on the network. The following shared folders are created automatically:

- ◆ Photos
- ◆ Music
- ◆ Videos
- ◆ Software
- ◆ Public
- ◆ A personal folder for each user account

---

**IMPORTANT NOTE:** Each time a new user is added, a folder with that user's name is automatically created by the **Add User Account Wizard**. By default, a user is the only person with access to the folder with his name.

---

You can easily add more shared folders to meet your needs.

### To add a shared folder

1. Click the **Shared Folders** tab in the **Console**.
2. Click **Add** in the upper left of the window. You will be prompted to type a name for the new folder.
3. Complete the **Add a Shared Folder Wizard** (Fig. 20).



Fig. 20

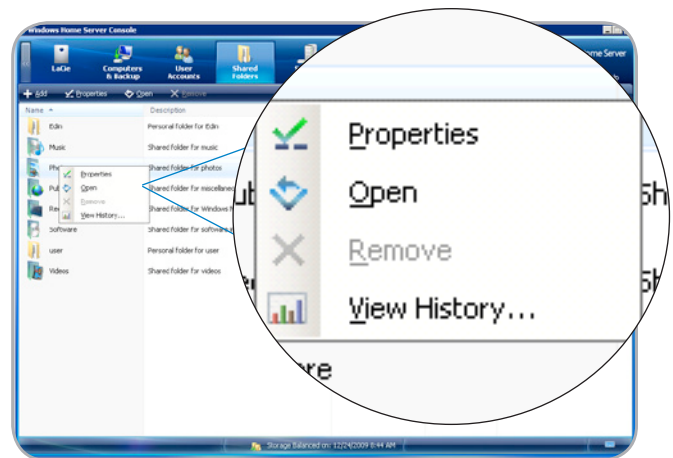

Fig. 21

### 3.2.1. Folder and File Duplication

To secure data, you have the option to duplicate folders. All files inside a duplicated folder are copied to other disks so that they will not be lost due to a single disk failure. Duplication at the folder level offers users precise control over which files should be protected.

When new folders are created, the box **Enable Folder Duplication** is checked by default (Fig. 20). You may deselect folder duplication if you wish to conserve disk space. Similarly, folders can be duplicated or deduplicated at any time.

1. Right-click on a folder (Fig. 21) and choose **Properties**.

[continued on the next page >>](#)

2. Check or, if the folder is currently duplicated, deselect the box **Enable Folder Duplication** (Fig. 22).

When folder duplication is enabled, the 5big Backup Server will copy files in the folder to other disks. If you have chosen to turn off folder duplication, the duplicate files from the folder will be deleted, providing more space on the Storage Hard Drives. LaCie recommends duplicating all folders since it guards files from being lost due to a disk failure.

### 3.2.1.1. Folder Duplication with a single disk in the enclosure

Please note the following behavior regarding Folder Duplication and Windows Home Server with only one disk in the pool of Storage Hard Drives:

- ◆ Folder Duplication requires a minimum of two hard drives. A 5big Backup Server with only one drive in the pool of Storage Hard Drives cannot enable Folder Duplication.
- ◆ Folder Duplication will not be enabled by default when the Connector is run on a 5big Backup Server with only one disk. However, you may enable Folder Duplication once additional disks have been added to the pool of Storage Hard Drives.

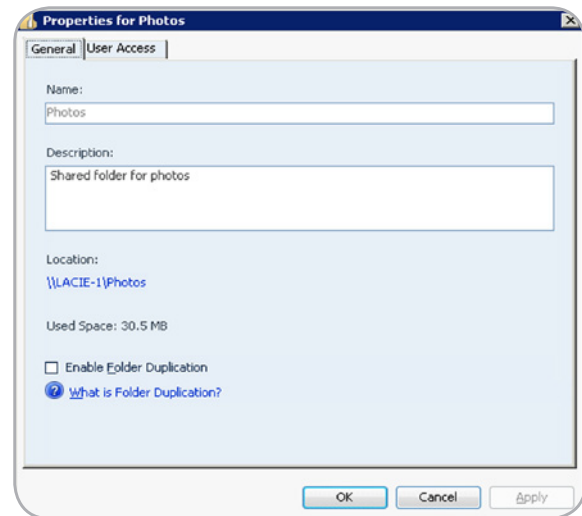

Fig. 22

### 3.3. Computer Backups

By default, all of the hard drive volumes on each computer are backed up every night after you install the Connector software. You may change the backup schedules to meet the needs of your business.

#### To customize a computer backup

1. Click the **Computers & Backup** tab in the **Console**. (Fig. 23).
2. Right-click the computer that you want to customize, and then click **Configure Backup**.
3. Complete the **Backup Configuration Wizard** to choose hard-drive volumes to back up and, if applicable, to exclude folders that do not require backup.

To make changes without using the **Backup Configuration Wizard**:

1. Click **Settings** in upper right corner of the **Console**.
2. Choose **Backup** from the list on the left of the **Settings** window (Fig. 24).
3. Adjust backup settings such as time of day, how long to store backups, etc. (Fig. 25)

---

**IMPORTANT INFO:** LaCie recommends using the 5big Backup Server in a small network environment with a maximum of ten Windows workstations. Additional Mac stations may also access data on the 5big Backup Server.

---

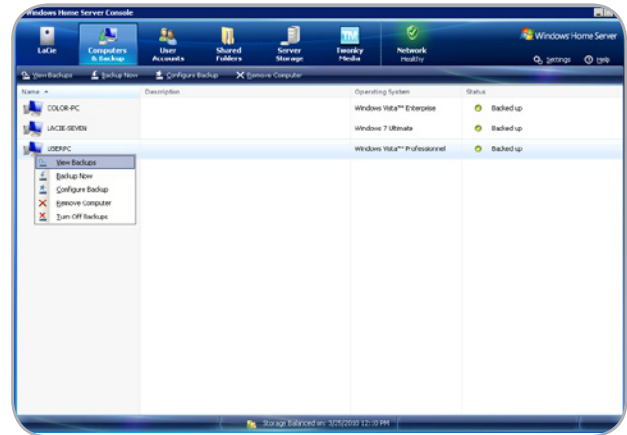

Fig. 23



Fig. 24

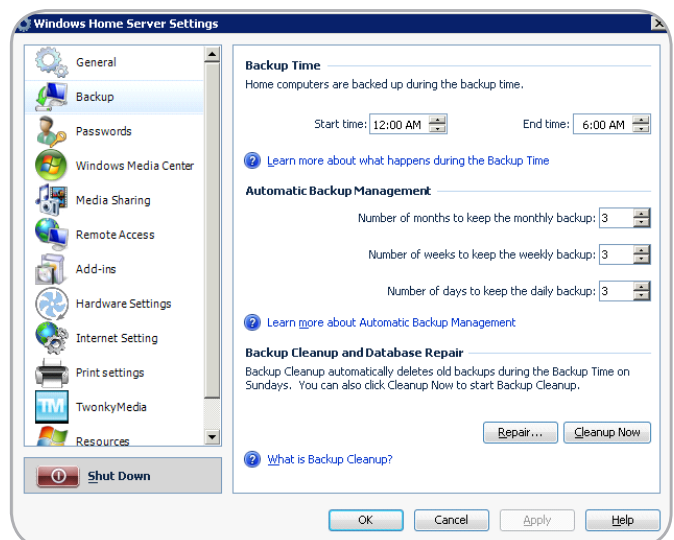

Fig. 25

### 3.4. Server Storage

If you want to add more storage to the 5big Backup Server, you can insert internal hard drives into empty slots (see 6.1. *Disk Installation*), or attach external USB 2.0 and/or eSATA hard drives (1.5. *Windows Home Server and the 5big Enclosure Disks*). It is not necessary to turn the 5big Backup Server off when adding new storage. Use the **Server Storage** tab to manage the disks.

Since it contains the server operating system, Disk 1 is listed in **Storage Hard Drives** by default. Depending upon your 5big Backup Server hard drive configuration, disks 2, 3, 4, and 5 are listed as **Non Storage Hard Drives** (Fig. 26). Follow the directions below to add **Non Storage Hard Drives** to the pool of **Storage Hard Drives** (see 1.5. *Windows Home Server and the 5big Enclosure Disks* for physical disk assignments).

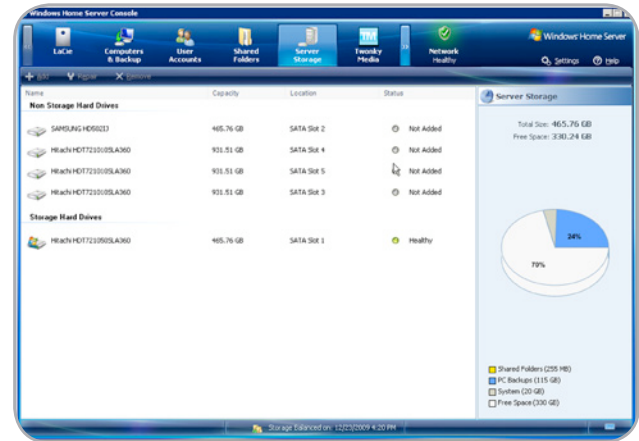

Fig. 26

---

**IMPORTANT INFO:** If you add an external USB hard drive, use a USB 2.0 hard drive. Both your computer hardware and your hard drive must support USB 2.0 for optimal performance. Using USB 1.1 devices can cause poor performance and unpredictable results.

---

**IMPORTANT INFO:** Disk 1 (see 1.5. *Windows Home Server and the 5big Enclosure Disks* for physical disk assignments) contains the Windows Home Server operating system. While other drives may be removed from the Storage Hard Drives, the 5big Backup Server requires Disk 1 for proper operation and management of the system. Removing Disk 1 while the 5big Backup Server is in use may cause a loss of data and will make the system unavailable.

---



Fig. 27

**CAUTION:** A **Non Storage Hard Drive** will be formatted when it is added to the pool of **Storage Hard Drives**. Make sure to copy all files that you want to save from a **Non Storage Hard Drive** before adding it to the **Storage Hard Drives**.

---

#### To add a disk to Storage Hard Drives

1. Connect or install the hard drive. Turn on the hard drive if applicable (i.e. an external USB 2.0 hard drive).
2. Click the **Server Storage** tab.
3. Under **Non Storage Hard Drives**, right-click the new hard drive, and then click **Add** (Fig. 27).

continued on the next page >>



- Complete the **Add a Hard Drive Wizard** to format the hard drive and to add it to your server storage (Fig. 28). You may also choose to assign new disks as backup storage for data stored on the 5big Backup Server (Fig. 29).

See section 6. *Removing and Installing New Disks* for more information.

### To remove a disk from Storage Hard Drives

- Click the **Server Storage** tab.
- Under **Storage Hard Drives**, right-click the disk for removal, and then choose **Remove** (Fig. 30).
- All of the files will be safely removed from the hard drive before you disconnect it. You risk losing data if you improperly remove a drive while the 5big Backup Server is in operation.

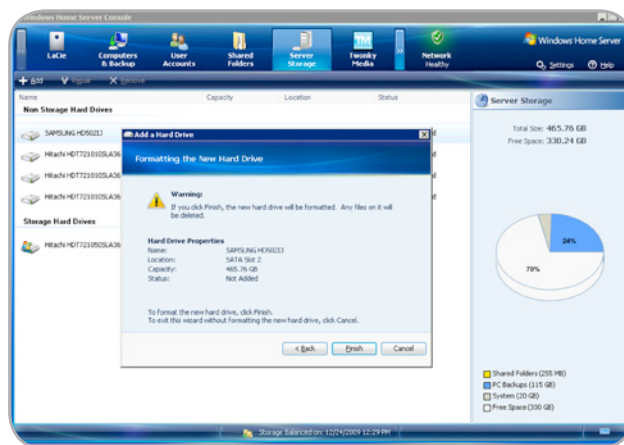

Fig. 28

---

**IMPORTANT INFO:** Configurations that include a limited amount of drives may not have sufficient space to retain the data from the disk that is being removed. You must have enough free space in the pool of Storage Hard Drives to copy data from the disk that you wish to remove.

---

### 3.4.1. Backup Drives Larger Than 2TB

A large capacity external disk is ideal for backing up your 5big Backup Server. See the LaCie [Technical Brief](#) for precise details on backing up your 5big Backup Server data to external USB 2.0 and eSATA drives. You may also use one or more drives within the 5big enclosure to backup Windows Home Server data.

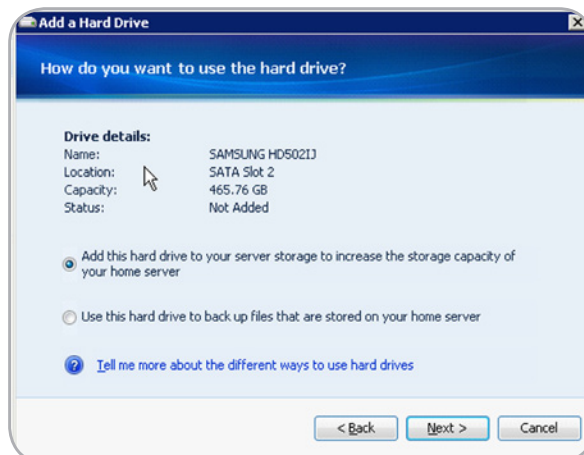

Fig. 29

---

**IMPORTANT INFO:** Drives larger than 2TB must be formatted using GPT for Windows Home Server. Format the drive(s) in Windows Disk Management before launching the Windows Home Server Console.

---

### 3.4.2. Disks Larger Than 2TB and the Windows Home Server Storage Hard Drives

Windows Home Server cannot add more than 2TB of a single disk to its pool of Storage Hard Drives. For example, if you add a 3TB non-LaCie drive into the pool of Storage Hard Drives, Windows Home Server will only use 2TB of its capacity. The remaining storage will be placed in the System as unavailable.

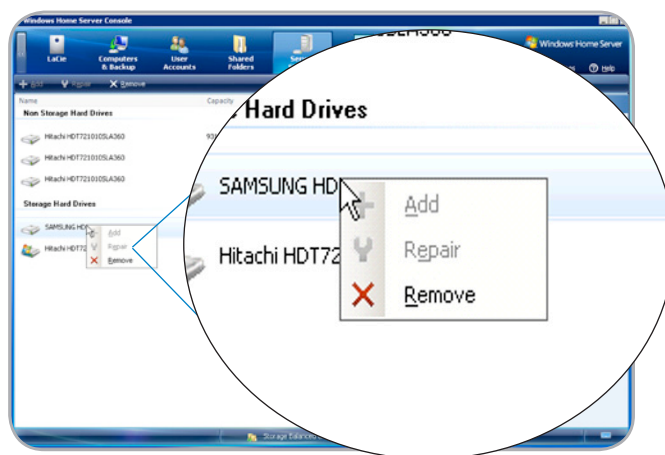

Fig. 30



### 3.5. Windows Home Server Settings

Click **Settings** (Fig. 31) to configure the following items:

#### General

- ◆ Date and time
- ◆ Regional settings
- ◆ Windows Update
- ◆ Customer Experience Improvement Program
- ◆ Configure Windows error reporting

**NOTE:** LaCie highly recommends checking the options for **Customer Experience Improvement Program** and **Windows Error Reporting** (Fig. 33) in **Settings>General**.

#### Backup

- ◆ The Backup Time(s)
- ◆ Automatic Backup Management
- ◆ Run Backup Cleanup

#### Passwords

- ◆ Change the 5big Backup Server password.
- ◆ Change the User Accounts Password Policy.

#### Media Sharing

Media Library Sharing for the Music, Photos, and Videos shared folders. Once configured, you can stream digital media from the 5big Backup Server to a device that supports Windows Media Connect.

#### Remote Access

- ◆ Web site connectivity
- ◆ Domain name
- ◆ Broadband router
- ◆ The settings for your 5big Backup Server web site.

#### Add-ins

Install and uninstall Add-ins.

continued on next page >>



Fig. 31

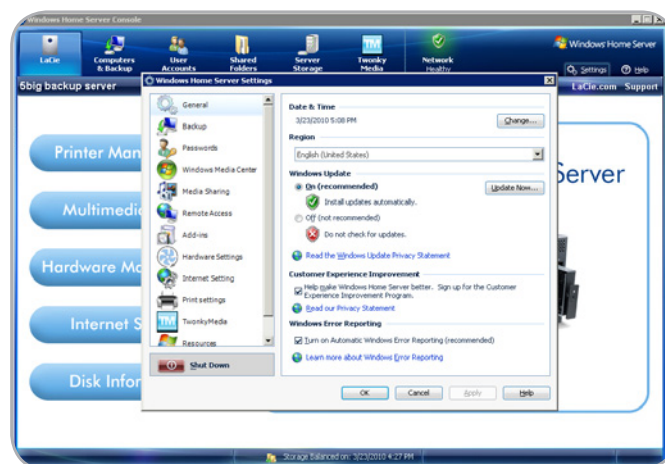

Fig. 32

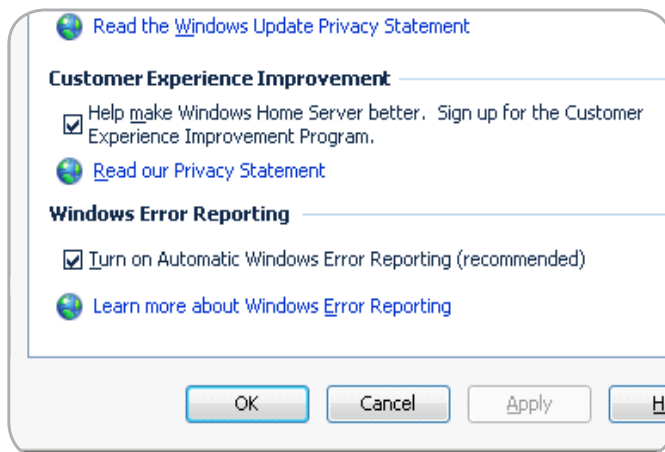

Fig. 33

**Resources**

- ◆ View hardware information about your 5big Backup Server.
- ◆ View the version of software information.
- ◆ Learn more about your 5big Backup Server.
- ◆ Connect to the 5big Backup Server.
- ◆ Community
- ◆ Contact Product Support.

In addition, you can shut down or restart the 5big Backup Server from the **Settings** dialog box by clicking **Shut Down** (Fig. 34). A prompt will appear to shut down or restart the 5big Backup Server.

For more information about the **Settings**, click **Help** on the **Settings** dialog box.

---

**IMPORTANT INFO:** While one hopes never to experience a problem, it is critical to prepare for all eventualities. Therefore, soon after setting up your network server, LaCie highly recommends that you create a system recovery USB 2.0 flash drive. See [7. Recovery](#) for further details.

---

### 3.5.1. Network Healthy/Network Critical and Important Updates

The normally green **Network Healthy** icon (Fig. 35) on the right of the **Console** may turn red at times, noting **Network Critical** (Fig. 36). Click once on the **Network Critical** icon to view the problem(s) encountered by the system. You may find notices for virus and/or spyware protection on some of the workstations connected to the 5big Backup Server. You can choose to address the issue on the workstation(s), or select **Ignore this issue** (Fig. 37). The **Network Critical** icon becomes **Network Healthy** when all items on the list have been fixed or ignored.

The **Network Critical** icon can appear when a major software update is required. When set to **Install updates automatically** in **Console>Settings>General**, the 5big Backup Server will periodically search for and install updates to Windows Home Server on its own. However, for major updates, the system will prompt you to initiate the process.

For automatic updates to work properly, the 5big Backup Server must have a connection to the Internet.

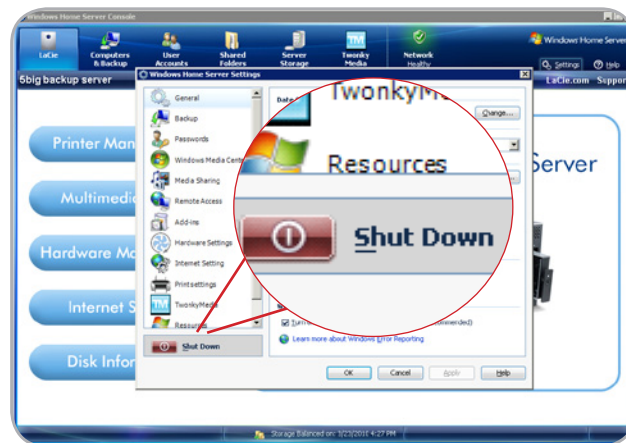

Fig. 34



Fig. 35



Fig. 36

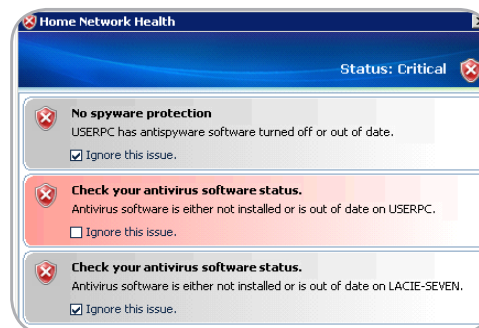

Fig. 37

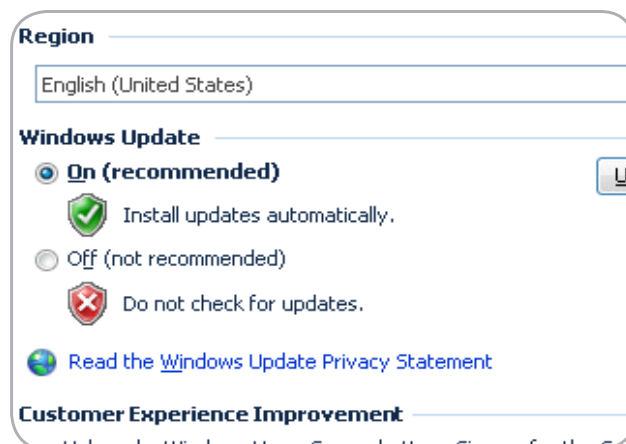

Fig. 38

## More Information

Look for more information about Windows Home Server from the following locations:

- ◆ Click **Help** on the Windows Home Server Console to open Windows Home Server Console Help.
  - ◆ On a home computer, right-click the Windows Home Server task tray icon, and then click **Help** to open Windows Home Server Help.
  - ◆ For more information about Windows Home Server documentation, see the Microsoft Web site: <http://go.microsoft.com/fwlink/?LinkID=85098>
  - ◆ To share ideas and information with other Windows Home Server enthusiasts, see the Windows Home Server Community Forums Web site: <http://go.microsoft.com/fwlink/?LinkId=83211>
  - ◆ To research troubleshooting tips, see the Microsoft Web site: <http://go.microsoft.com/fwlink/?LinkId=88097>
-

## 4. LaCie Dashboard

The LaCie Dashboard provides additional features for managing your 5big Backup Server including Printer Management, Multimedia Server, Hardware Management, Internet Settings, and Disk Information.

### Accessing the LaCie Dashboard

Click **LaCie** in the **Console**.

### 4.1. Printer Management

You can use your LaCie 5big Backup Server as a printer server for USB printers. Simply connect a USB printer to one of the 5big Backup Server's external USB 2.0 ports and follow the steps below.

1. Select the **LaCie** in the **Console**.
2. From the list of features on the left, select **Printer Management** (Fig. 39).
3. Select **Manage Printers** (Fig. 39) next to the printer image.
4. Options include **Properties** of current printers and **Add Printer** to the network (Fig. 40). Choosing **Add Printer** launches the **Welcome to the Add Printer Wizard** (Fig. 41).

**IMPORTANT INFO:** Please note that you cannot run a printer installation program from the **Console**. To install a printer on your 5big Backup Server, you must have the driver file(s) that are shipped with the printer. LaCie highly recommends that you copy the printer driver file(s) to a shared folder on your 5big Backup Server (i.e. Shared Folders\Software\Printer Drivers). When running the Windows Printer Setup Wizard, browse to the directory that contains the printer driver file(s) (i.e. Shared Folders\Software\Printer Drivers) to complete the installation.



Fig. 39

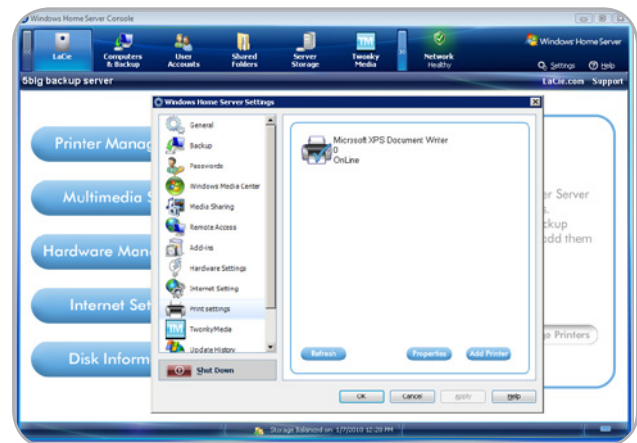

Fig. 40

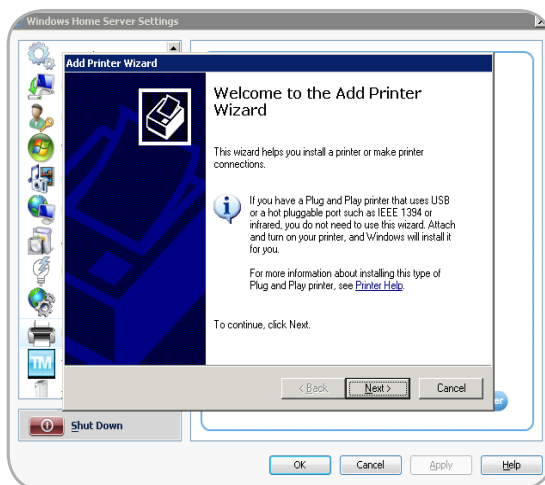

Fig. 41

## 4.2. Multimedia Server

Stream movies, music, and photos directly from your 5big Backup Server to devices on the network such as:

- ◆ Computers
- ◆ DLNA/UPnP compatible digital media adapters (i.e. game systems)

Using Windows Media Center (3.5. *Windows Home Server Settings*) or TwonkyMedia Server, you can choose who has the right to share the media files stored on the 5big Backup Server.

For TwonkyMedia:.

1. Select **LaCie** in the **Console**.
2. From the list of features on the left, select **Multimedia Server** (Fig. 42).
3. Select **Access** to the right of the television image (Fig. 42).
4. Select **TwonkyMedia** on the left of the screen to manage all your media files using TwonkyMedia.

Tabbed menus enable you to choose the media files you want to share and how to maintain your libraries (Fig. 43).



Fig. 42

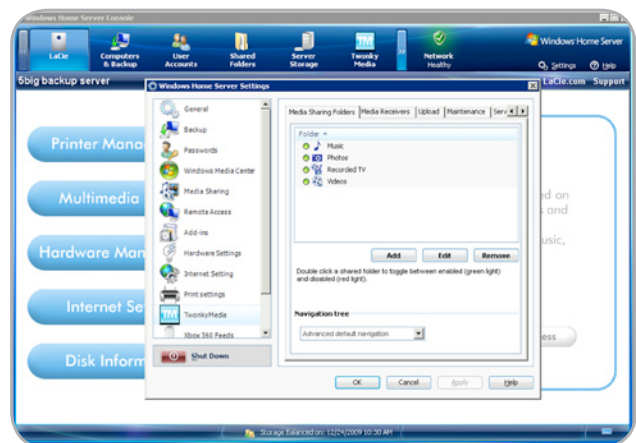

Fig. 43



### 4.3. Hardware Management

LaCie recommends taking advantage of the Hardware Management feature to manage and conserve energy usage by your 5big Backup Server. Adjust the settings for fan rotation, LED intensity, and Energy Management.

1. Select **LaCie** in the **Console**.
2. From the list of features on the left, select **Hardware Management** (Fig. 44, a).
3. Select **Access** (Fig. 44, b).
4. Select the hardware setting you want to change (Fig. 45).



Fig. 44

#### FAN rotation

- ◆ **Optimal** - the 5big Backup Server will determine a fan speed based upon the system temperature. To conserve energy, LaCie recommends this setting.
- ◆ **Maximum** - the fan will always run at its highest speed.

#### LED Intensity

- ◆ The default is "7", which is the brightest setting for the front LED. By moving the slider, you may turn the brightness down to conserve energy.

#### Energy management

- ◆ In the event of a power failure, you can decide how the 5big Backup Server will react once power is restored. Choose between: powering on; staying off; or, rebooting in the system's last state before the power was lost. You must reboot the 5big Backup Server after making changes to this setting.
- ◆ Power to the USB ports can remain on or off when the 5big Backup Server is in standby. To conserve energy, choose "No".
- ◆ Energy Saving mode provides a choice between "Standby" and "Hibernate". Standby places the system in a standard sleep mode, with the 5big Backup Server ready to awaken when used. With Hibernate, the 5big Backup Server conserves more energy but will take longer to awaken when being accessed.
- ◆ MAC Address is an easy copy and paste feature (Fig. 46). Click on the icon to copy the MAC address to the Clipboard then paste it in the program of your choice. One example is a program that offers a Wake on LAN feature to access the 5big Backup Server from a remote location.



Fig. 45

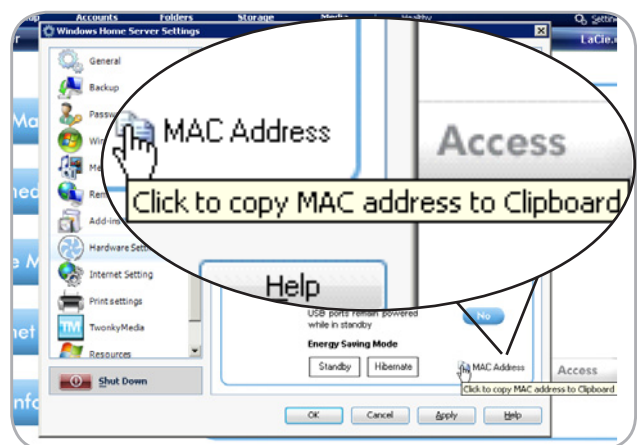

Fig. 46

## 4.4. Internet Settings

If your network does not have a direct connection to the Internet or you manage Internet traffic via another server, choose **Internet Settings** to assign a proxy server to your 5big Backup Server.

1. Select **LaCie** in the **Console**.
2. From the list of features on the left, select **Internet Settings** (Fig. 47).
3. Select the **Internet Settings** button to the right of the globe image (Fig. 47).
4. Add the proxy server information (Fig. 48).

---

**IMPORTANT INFO:** In order to facilitate critical updates, your 5big Backup Server must have a connection to the Internet.

---



Fig. 47

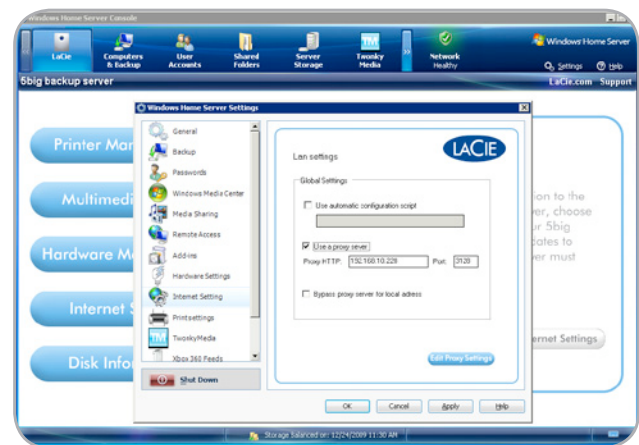

Fig. 48

## 4.5. Disk Information

Disk Information offers a quick reference for the health of the hard drives in your 5big Backup Server. Disk information includes:

- ◆ Capacity
- ◆ Manufacturer
- ◆ Model
- ◆ Health status

The color of the drive LEDs in Disk Information:

- ◆ Blue indicates a healthy disk (*Fig. 49*)
- ◆ Black means the disk slot is empty (*Fig. 50*)
- ◆ Red indicates disk failure (*Fig. 51*)

If the Disk Information health status LED is not blue, please search the front and rear LEDs of the 5big Backup Server to determine the exact nature of the problem. Section 8. *LED Indicators* offers definitions for LED behavior.



Fig. 49



Fig. 50



Fig. 51



## 5. Mac Support

Mac clients may access the 5big Backup Server to share data with other workstations on the network and to enable backups using Time Machine®.

---

**IMPORTANT INFO:** The Server Connector CD is only compatible with Windows-based systems. Please do not attempt to install the Connector on a workstation running the Macintosh operating system.

---

### 5.1. Mac Clients on the 5big Backup Server

Mac clients may access volumes on the 5big Backup Server without the aid of the Connector. From a **Finder Window** or **Connect to Server**, a Mac client can search the network for the 5big Backup Server and mount shared folders (volumes) to access files.

#### 5.1.1. Accessing Shared Folders (Volumes)

The administrator for the 5big Backup Server should create a user account for each Mac client (Fig. 52) similar to Windows users and assign the necessary permissions to access shared folders. See 3.1. *User Accounts* for further information on creating user accounts.

Once an account is created, a Mac client may open shared folders by using a **Finder Window** or **Connect to Server**.

#### Finder Window

1. From the Finder, go to **File>New Finder Window**.
2. Search **SHARED** on the left of the Finder Window to see the list of available network servers (Fig. 53). The 5big Backup Server should appear on the list under the name created during the Setup. In this example, we are using the default, "5bigbackup".
3. Click on the icon for your 5big Backup Server in **SHARED** (Fig. 53).
4. Click **Connect As...** (Fig. 54) to log on.
5. A pop-up window will appear to log on. Select **Registered User** and enter the **Name** and **Password** created in the Windows Home Server Console.

continued on the next page >>

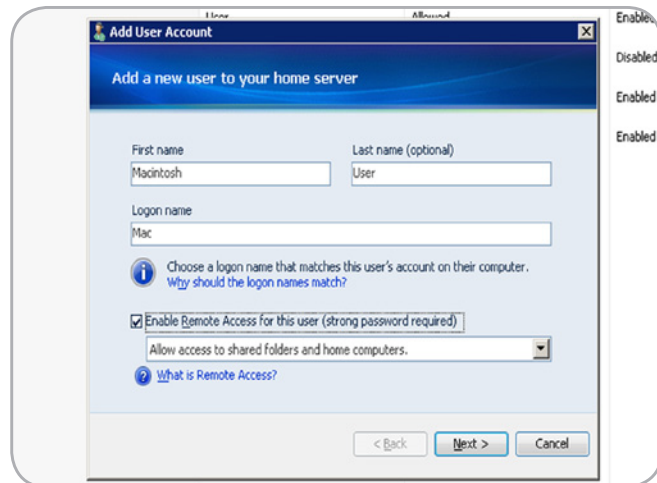

Fig. 52

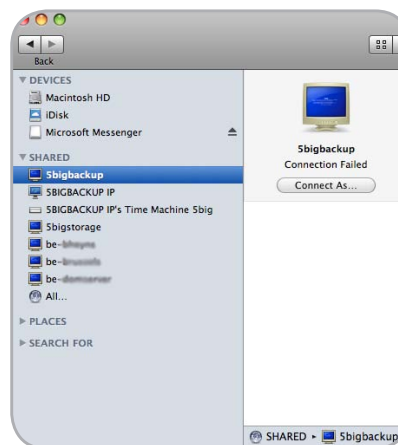

Fig. 53

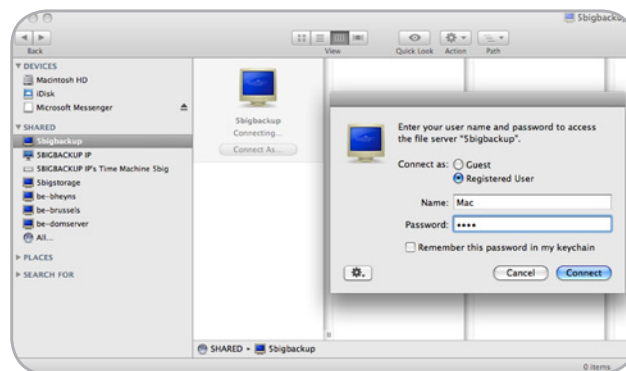

Fig. 54

6. The shared volumes are now available (Fig. 55).

### Connect to the Server

1. From the Finder, go to **Go>Connect to Server...**
2. Enter the 5big Backup Server name or its IP address (Fig. 56).
3. A pop-up window will appear to log on. Select **Registered User** and enter the **Name** and **Password** created in the Windows Home Server Console (Fig. 57).

[continued on the next page>>](#)

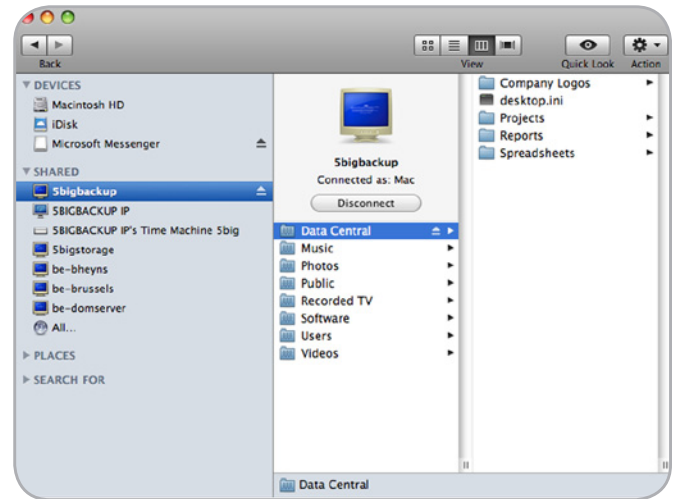

Fig. 55

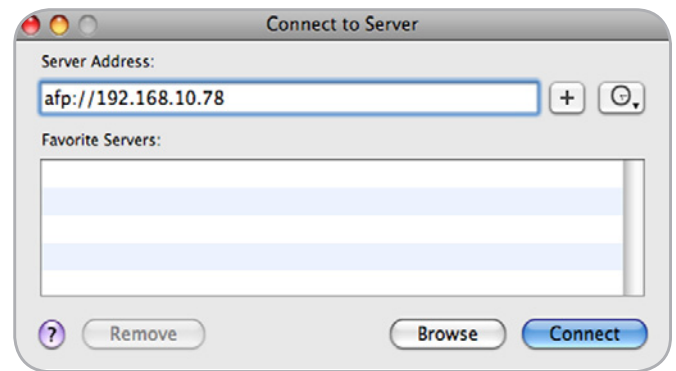

Fig. 56



Fig. 57

4. The shared volumes are now available (Fig. 58).

### 5.1.2. Time Machine

Once it has been configured on your network, the 5big Backup Server will appear on the list of target volumes for Time Machine backups.

1. On the Mac client, go to the **Apple Pulldown Menu>System Preferences>System>Time Machine**.
2. Select **Change Disk...** (Fig. 59).
3. Select the name of your 5big Backup Server from the list of available target disks. Click **Use for Backup**. (Fig. 60)

The next scheduled backup will occur on your 5big Backup Server.

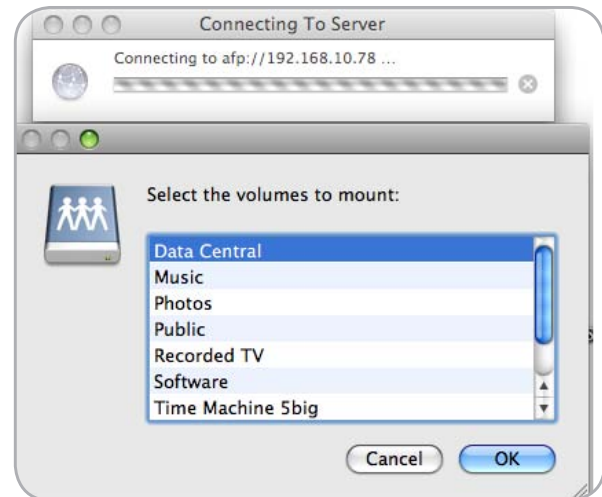

Fig. 58



Fig. 59

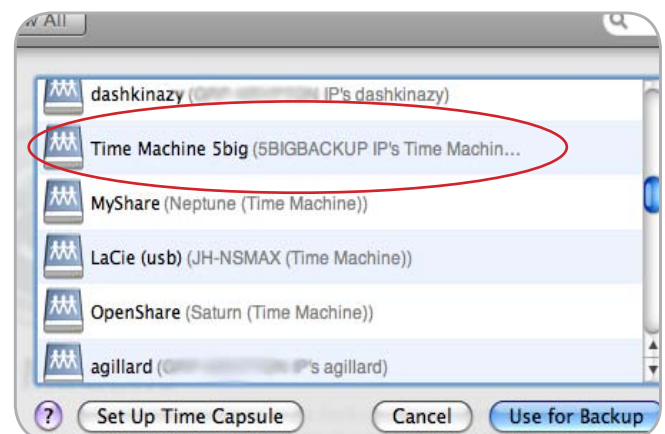

Fig. 60

### 5.1.3. Managing and Monitoring Mac Clients

While Mac clients do not appear in the **Console**, you may manage and monitor them on a Windows-based workstation using **ExtremeZ-IP Administrator**. The program is located in the 5big Backup Server shared folder **Software**.

1. From a Windows Vista or Windows 7-based workstation, go to **Network > 5bigbackup [or, the name of your 5big Backup Server] > Software** (Fig. 61)
2. Right-click on **ExtremeZ-IP Administrator** and choose **Run as administrator** (Fig. 62). Selecting **Open** may not launch the program.
3. If you are not logged onto the workstation as an administrator, Windows will ask for a login and password.

[continued on the next page >>](#)

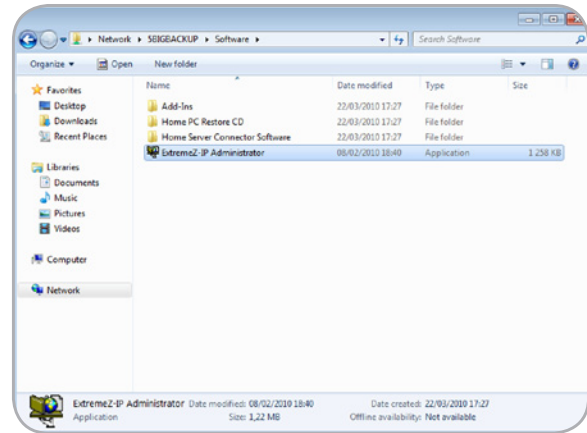

Fig. 61

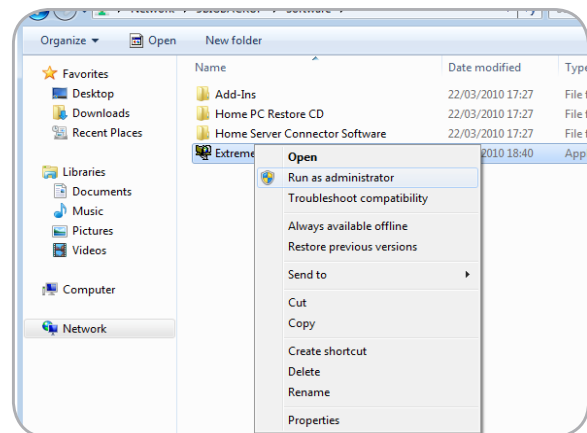

Fig. 62

4. A window will open to confirm the name of the server (Fig. 63). Click **OK**.
5. **ExtremeZ-IP Administrator** is now available. See the manual for ExtremZ-IP for further information on how to manage and monitor Mac clients connected to the 5big Backup Server. The manual may be found on the **Connector CD > Documents > ExtremeZ-IP Manual**.

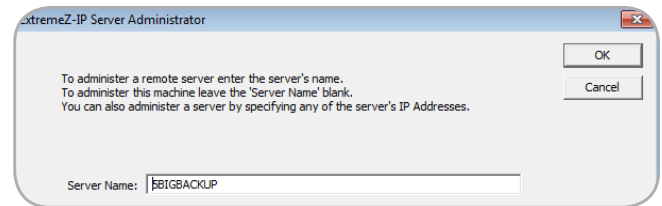

Fig. 63

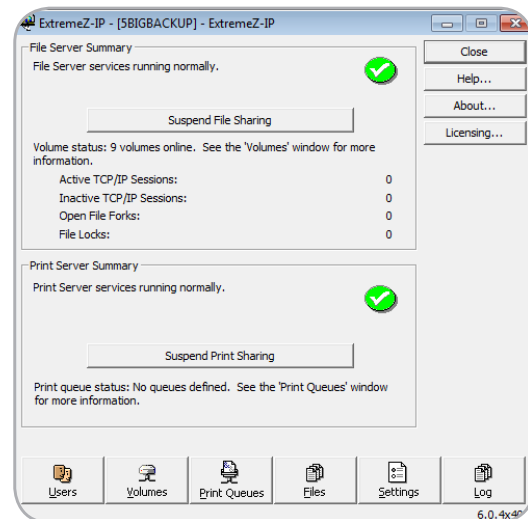

Fig. 64

## 6. Removing and Installing New Disks

### 6.1. Disk Installation

If the 5big Backup Server experiences disk failure or you have purchased a new disk to add to the pool of Storage Hard Drives, please follow the directions below for removing and installing disks. To comprehend the meaning of LED activity, please see [8. LED Indicators](#).

---

**IMPORTANT INFO:** In the event that an individual hard disk fails in the LaCie 5big Backup Server, contact your LaCie reseller or LaCie Customer Support for technical assistance. If the problem drive was purchased from LaCie and is within the warranty period, please replace it with a hard drive provided by LaCie. LaCie will not replace a non-LaCie hard drive or any hard drive not purchased from LaCie.

---

**5big Backup Server single disk:** See [6.1.1. Fastening a non-LaCie Hard Disk to a 5big Enclosure Drive Tray](#) once you have removed an empty 5big enclosure drive tray.

Please note the following before replacing or adding a hard drive:

- ◆ If you want to remove a USB 2.0, eSATA, or enclosure hard drive from your 5big Backup Server, use **Remove** on the **Console Server Storage** tab. Right-click the hard drive that you want to remove, and then click **Remove**. Windows Home Server will safely move all of the files off of the hard drive before you disconnect it. You risk losing data if you improperly remove a drive while the 5big Backup Server is in operation. See [3.4. Server Storage](#) for more information.
- ◆ When installing a replacement disk, make certain to choose the slot with the problem drive.
- ◆ The LaCie 5big Backup Server drives may be hot after continuous use. Please use caution when removing one or more drives from the enclosure.
- ◆ Use care when inserting or removing more than one disk while the 5big Backup Server is powered on. If disks are rapidly inserted or removed while the 5big Backup Server is turned on, the system may not function properly or the drives will lose recognition. You must wait at least ten seconds between each insertion or removal of a hard drive.

[continued on the next page>>](#)

### Remove a drive tray:

If you are adding a non-LaCie disk to an empty slot in the 5big Backup Server, choose a drive tray that does not hold a drive. LaCie recommends inserting new drives in the order of the numbered slots, from left to right. For example, if the first slot on the left (Slot 1) contains the sole drive in the enclosure, choose the second slot from the left (Slot 2) for the next drive. See [6.1.1. Fastening a non-LaCie Hard Disk to a 5big Enclosure Drive Tray](#) once you have removed an empty drive tray.

1. Use the included drive lock tool to unlock the drive tray. Turn the lock until it is vertical. (Fig. 65)
2. Place your index finger into the space behind the handle. (Fig. 66)
3. Draw out the drive tray handle and carefully extract it. Please use caution when removing the drive tray. (Fig. 67).

### Insert a disk:

1. Make certain that the replacement or new drive is securely fastened to a drive tray. See [6.1.1. Fastening a non-LaCie Hard Disk to a 5big Enclosure Drive Tray](#) if you are adding a non-LaCie drive.
2. Carefully insert the drive tray into the empty drive slot. You will feel resistance when the drive tray is most of the way in the bay. Gently push the drive tray handle firmly until you feel the drive snap into place. The drive tray handle should be flush with the back of the 5big enclosure.
3. Use the drive lock tool to lock the drive in place.
4. The blue LED will continue to blink until the drive is added to the pool of **Storage Hard Drives** (see [6.2. Adding a new disk to the 5big Backup Server storage](#) for instructions on how to add drives to **Storage Hard Drives**). If the disk LED does not blink, try the steps for inserting a disk once more.

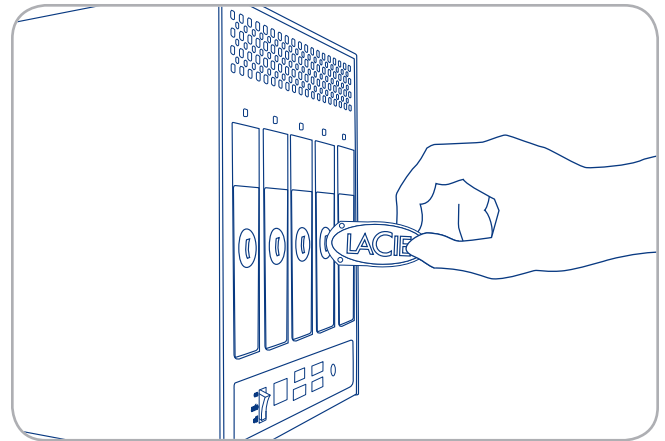

Fig. 65

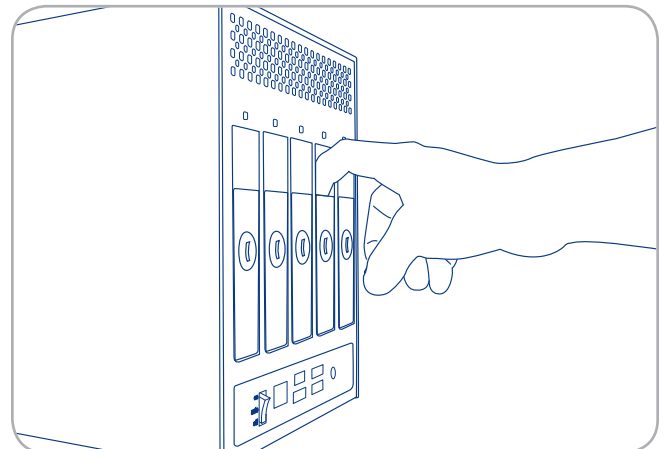

Fig. 66

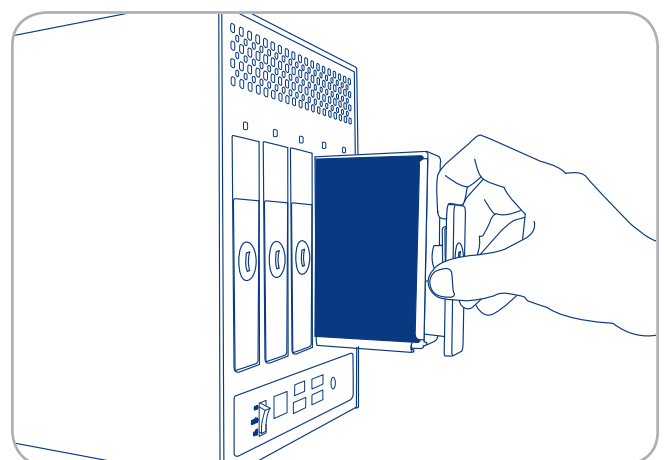

Fig. 67

### 6.1.1. Fastening a non-LaCie Hard Disk to a 5big Enclosure Drive Tray

**IMPORTANT INFO:** Drives sold by LaCie are the preferred choice when using your 5big Backup Server. LaCie disks specially prepared for the 5big enclosure are tested and shipped in a drive tray for easy installation. Additionally, all 5big hard drives include a 3-year warranty. Visit [www.lacie.com](http://www.lacie.com) for more information on purchasing a 5big disk drive.

Please note the following before fastening your non-LaCie hard drive to the drive tray:

- ◆ Only 3.5" SATA II drives may be used in the 5big enclosure. Please visit the Support page at [www.lacie.com](http://www.lacie.com) for a list of drives that have been tested by LaCie. LaCie cannot guarantee performance or compatibility with the 5big Backup Server when using drives that have not been tested by LaCie.
- ◆ Windows Home Server cannot add more than 2TB of a single disk to its pool of Storage Hard Drives. For example, if you add a 3TB non-LaCie drive into the pool of Storage Hard Drives, Windows Home Server will only use 2TB of its capacity. The remaining storage will be placed in the System as unavailable.
- ◆ Use only the screws supplied in your packaging when fastening the non-LaCie hard drive to the drive tray (Fig. 68)
- ◆ To avoid potential problems caused by electrostatic discharge (ESD), it is recommended that you do not touch the hard drive's printed circuit board (Fig. 69 - *To prevent ESD, avoid touching the hard drive printed circuit board*). As a further precaution against ESD, please use an anti-static wristband or an anti-static mat to ground yourself when handling the hard drive.

continued on the next page >>

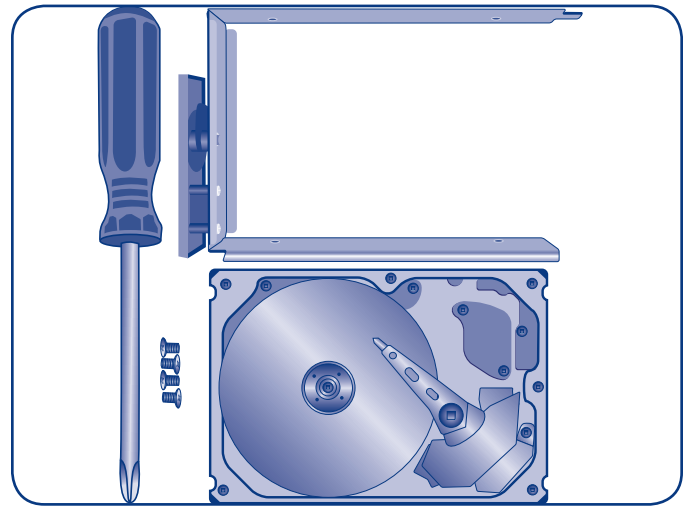

Fig. 68

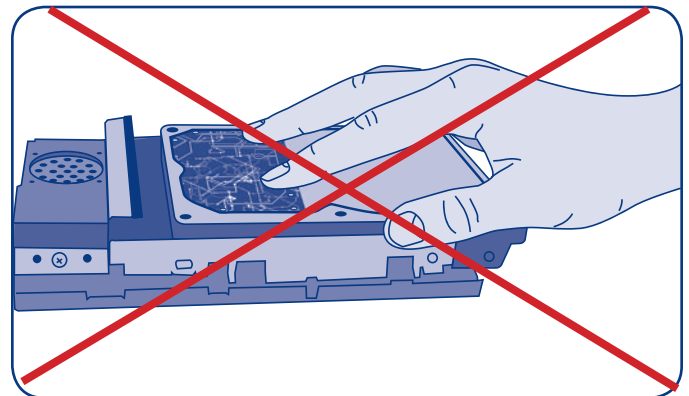

Fig. 69 - To prevent ESD, avoid touching the hard drive printed circuit board



### Fastening a disk to the drive tray:

1. Find a suitable work area with adequate space and a flat, even surface.
2. Locate the empty 5big drive tray and four drive tray screws included in your packaging. Do not fasten a disk to a 5big enclosure drive tray with alternative screws. Doing so may damage the drive tray as well as your non-LaCie disk. Make certain that your non-LaCie 3.5" SATA II disk and a Phillips head screwdriver are within reach as well. Please confirm that the head of the screwdriver is the proper size for the drive tray screws provided by LaCie.
3. Place the empty drive tray onto the flat work area. The handle should be on the bottom left, with the lock icon pointing away from you (Fig. 70).
4. With its label side facing up, gently place the hard disk within the drive tray (Fig. 71). Please make certain that the printed circuit board is flat on the work space and the SATA connector is facing to the right. The four tray screw slots should be neatly aligned with the disk's four screw holes. If the screws are not aligned with the holes, check to see if the disk has been placed upside down within the tray.
5. Using the Phillips head screwdriver, carefully fasten all four screws into their slots. **Do not overly tighten the screws.** Doing so may negatively affect the integrity of the screw holes on the drive as well as the threads on the screws (Fig. 72).
6. Go to [6.1. Disk Installation](#) for details on inserting the disk tray into the 5big enclosure.

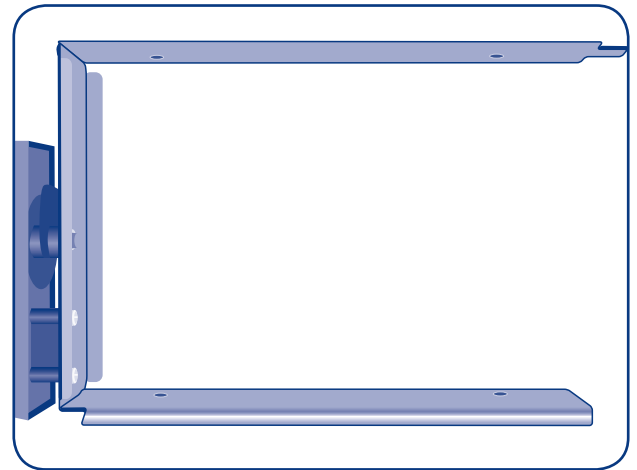

Fig. 70

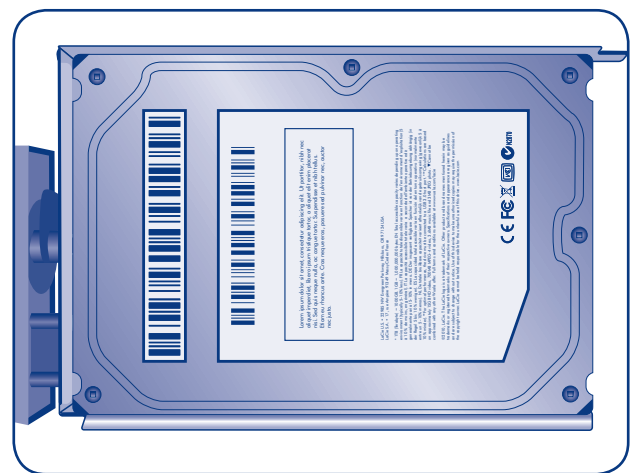

Fig. 71

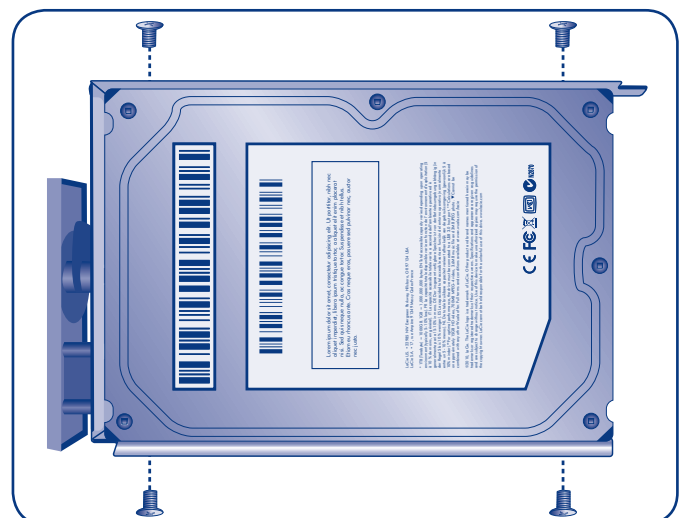

Fig. 72

## 6.2. Adding a new disk to the 5big Backup Server storage

1. Once the new drive is installed, select **Server Storage** in the Console.
2. The new drive will be listed under **Non Storage Hard Drives**. Click once on your new drive so that the +Add selection becomes active (Fig. 73).
3. Click once on +Add to launch the **Add a Hard Drive Wizard** (Fig. 74).
4. Follow the Wizard to include the new drive in the pool of **Storage Hard Drives**.
5. Once finished, the new hard drive should be listed under the section **Storage Hard Drives** (Fig. 75).

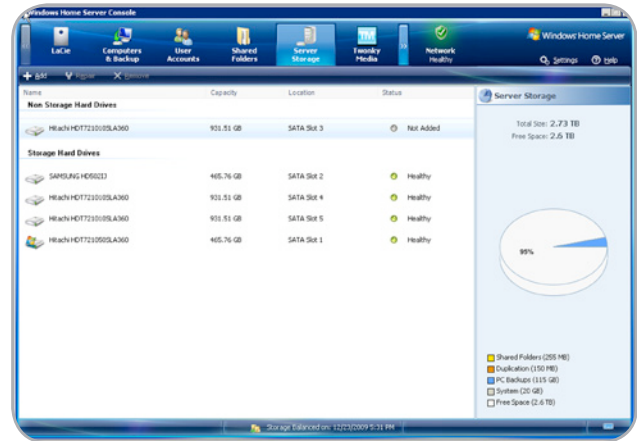

Fig. 73

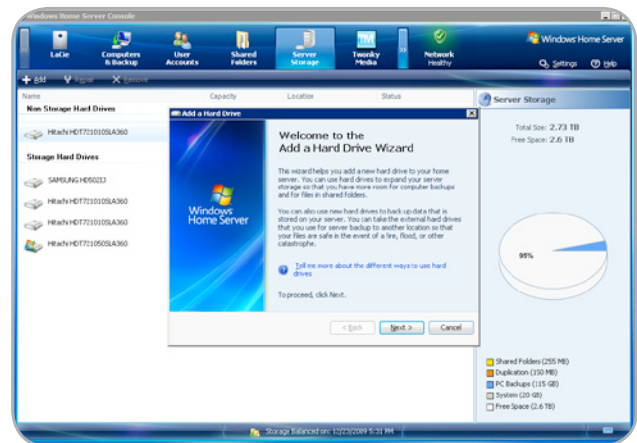

Fig. 74

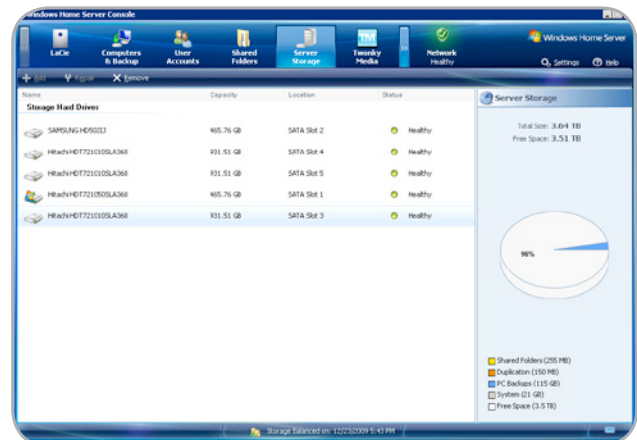

Fig. 75

## 7. Recovery

### 7.1. Recovery: 5big Backup Server

In case Windows Home Server or Disk 1 (the disk that hosts the operating system) encounter problems, the tools to restore or recover the server are included in the contents of your 5big Backup Server packaging ([7.1. Box Content](#)). The process requires booting the server from a system recovery USB 2.0 flash drive and running the 5big Backup Server Recovery DVD on a Windows workstation within the same network. When running the 5big Backup Server Recovery DVD, you will have the option to preserve data on the **Storage Hard Drives**, reformat Disk 1 alone, or erase all files by reverting the system back to factory settings.

While one hopes never to experience a problem, it is critical to prepare for all eventualities. Therefore, soon after setting up your network server, LaCie highly recommends that you create a server recovery USB 2.0 flash drive.

---

#### 7.1.1. Server Recovery USB 2.0 Flash Drive

Server Recovery Key is a program that guides you through the server recovery disk creation in a few easy steps. Server Recovery Key may be found within the contents of **Server Recovery DVD > Applications**.

Before starting, please note the following:

- ◆ Use a small capacity USB 2.0 flash drive (512 MB, for example) as a recovery disk. A USB 2.0 flash drive larger than 8GB may be problematic due to format conflicts. Do not use older USB 1.1 or USB hard drives as system recovery disks.
- ◆ Creating a system recovery USB 2.0 flash drive requires Windows Vista, Windows 7, or Windows Server 2008.

[continued on the next page >>](#)

1. Insert the Server Recovery DVD into a workstation's optical disk drive.
2. Insert a USB 2.0 flash drive into an available USB 2.0 port on the same workstation.

---

**IMPORTANT INFO:** Creating a server recovery USB 2.0 flash drive will erase any data that is stored on the USB 2.0 flash drive. Please backup data that you want to preserve before moving to the next step.

---

3. Launch Server Recovery Key (Server Recovery DVD>Applications>Server Recovery Key).
4. Please note the information on the welcome window (Fig. 76). Click **Next>** to continue.
5. Select the USB flash drive from the pulldown menu (Fig. 77). If there are more than one USB flash drives connected to your workstation, make certain to choose the target flash drive. Choosing the incorrect flash drive may delete data that you want to keep. Consider closing Server Recovery Key and removing all USB flash drives. Reinsert only the USB flash drive that you want to use as a server recovery disk.
6. Once the flash drive has been chosen, Server Recovery Key offers a green check mark indicating that the device is compatible (Fig. 78). If the flash drive is not compatible, a red "X" will appear.

---

**IMPORTANT INFO:** There are a great number of USB 2.0 flash drives manufactured by a wide range of companies. While many USB 2.0 flash drives from 512 MB to 4 GB should work as a recovery flash drive, LaCie cannot test every model. If Server Recovery Key experiences problems in creating the system recovery USB 2.0 flash drive, please try a different flash drive.

---

7. Click **Create Key>** to continue (Fig. 78).

[continued on the next page >>](#)

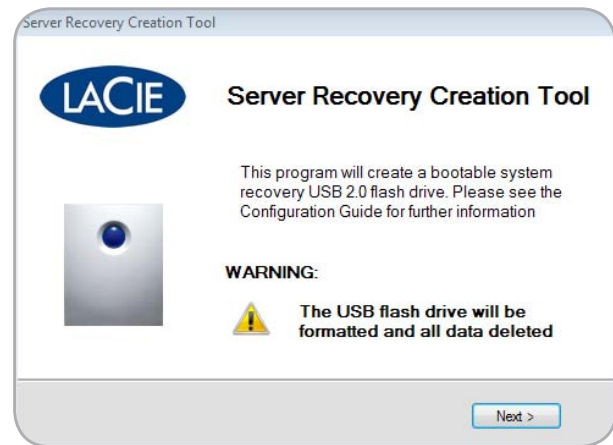

Fig. 76

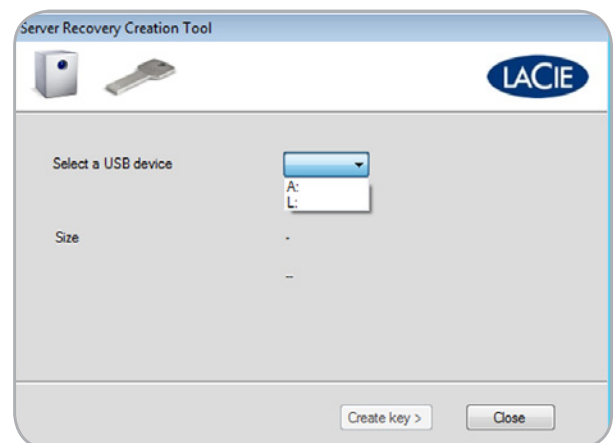

Fig. 77

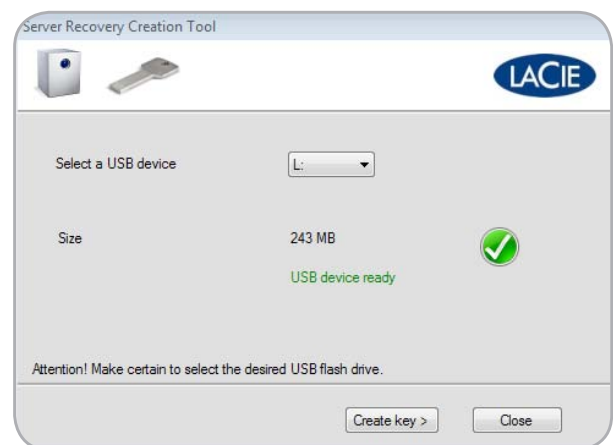

Fig. 78

8. A prompt will warn you that creating a USB recovery key will delete all data on the flash drive. Click **OK** to continue (Fig. 79).
9. Once finished, click **OK** (Fig. 81) and safely eject the USB flash drive. Keep the recovery key in a safe place so that it will be ready to boot the 5big Backup Server.

---

**IMPORTANT INFO:** Please note that the server recovery USB 2.0 flash drive is meant for the 5big Backup Server only and should not be used to boot a Windows workstation.

---

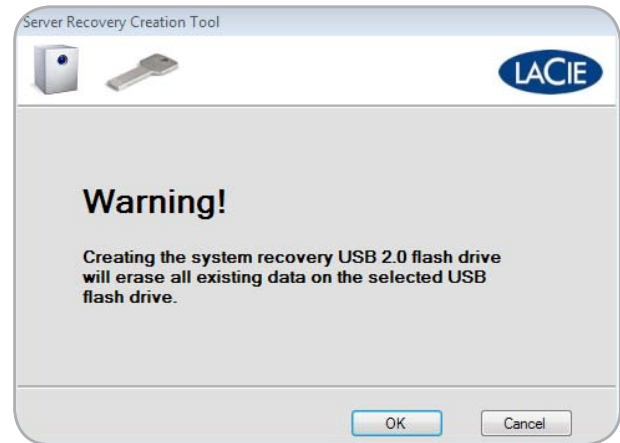

Fig. 79

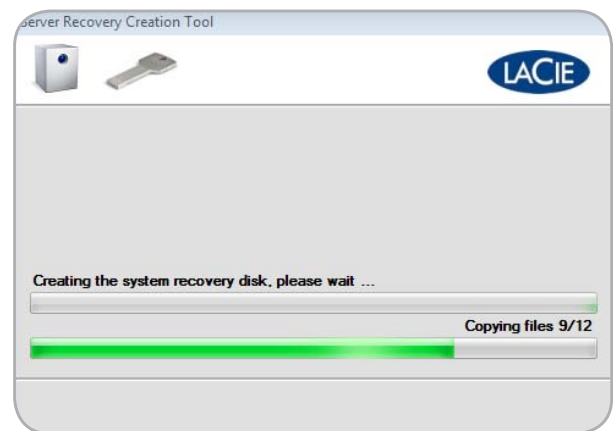

Fig. 80

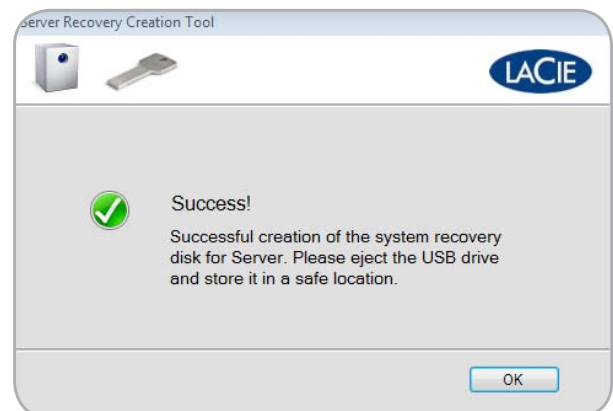

Fig. 81

## 7.1.2. 5big Backup Server Recovery

**IMPORTANT INFO:** As with most recovery operations, LaCie cannot guarantee that all files and settings will be restored. There is a very good chance that certain system settings, such as user and computer profiles, will have to be recreated. Add-in programs must be reinstalled after a recovery.

1. Make certain that all users and computers have logged off from the 5big Backup Server on the local network and, if applicable, from remote locations.
2. Turn off the 5big Backup Server by selecting Settings in the Console (Fig. 82, a), followed by Shut Down (Fig. 82, b).
3. Once the 5big Backup Server has shut down, plug the USB 2.0 flash key into one of its four USB 2.0 ports (1.4.2. Rear View).
4. To boot the 5big Backup Server in recovery mode:
  - ◆ Insert the pointed end of the drive lock tool into the system recovery button (1.4.2. Rear View).
  - ◆ While pushing the system recovery button, turn on the 5big Backup Server by pushing the front LED button.
  - ◆ Continue to push the system recovery button for two or three seconds.
5. The front LED blinks at a slower pace, indicating that it is booting from the recovery USB 2.0 flash drive.
6. Insert the 5big Backup Server Recovery DVD into a Windows workstation's optical disk drive. The workstation must be connected to the same network as the 5big Backup Server.
7. Go to **Server Recovery DVD > Applications > Server Recovery**. Launch **Server Recovery**.
8. Read the welcome page then click **Next>** (Fig. 83).
9. The Server Recovery will search for the 5big Backup Server on the network. Once it is found, click **Next>** (Fig. 84). If the 5big Backup Server is not found, please make certain that:
  - ◆ The workstation and the 5big Backup Server are on the same network.
  - ◆ The 5big Backup Server has booted from the USB recovery key.

continued on the next page>>

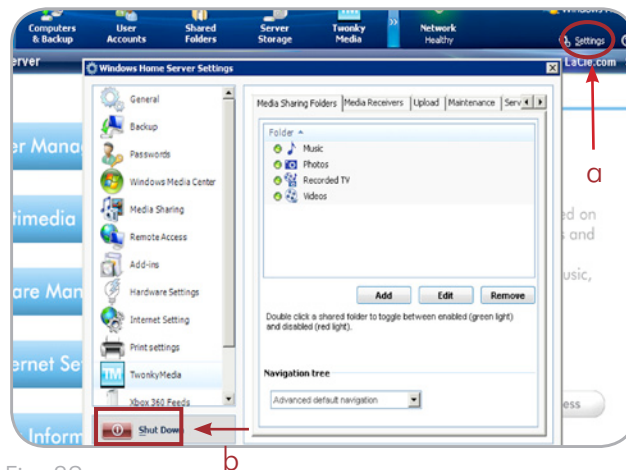

Fig. 82



Fig. 83

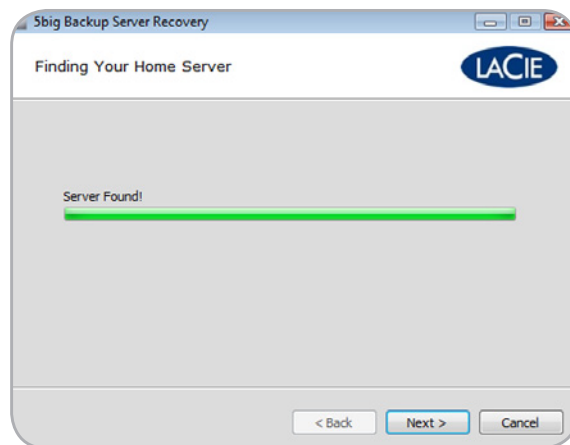

Fig. 84

10. The next window lists three recovery options (Fig. 85). While each choice enables you to run the Connector as if it were the first installation, there are different levels of drive formatting. Please read each description carefully in order to understand which option is best for you. Briefly:

- ◆ *System Partition Format*: The Windows Home Server operating system uses a portion of Disk 1 (see 1.5. *Windows Home Server and the 5big Enclosure Disks*). This option attempts to format only the operating system information before reinstalling a new version. This is the least destructive option.
- ◆ *Disk 1 Format*: All of Disk 1 (see 1.5. *Windows Home Server and the 5big Enclosure Disks*) will be formatted before the operating system is reinstalled. Data stored on Disk 1 will be deleted.
- ◆ *Factory Reset*: All connected drives (including USB and eSATA drives attached to the 5big Backup Server) will be formatted before the operating system is reinstalled on Disk 1 (see 1.5. *Windows Home Server and the 5big Enclosure Disks*). This option will delete all data on all the disks.

---

**IMPORTANT INFO:** No matter the level of formatting you choose, all User information will be deleted. You may add new users and run the Connector from each workstation on the network once the recovery has finished.

---

11. Select the best recovery mode and click **Next>** (Fig. 85).
12. Confirm the recovery mode and click **Next>** (Fig. 86). Please note that the example here is for a Factory Reset, which will delete all data. The notification window is different for the other two options.
13. The reinstallation will take some time. When the format has successfully completed, you will be prompted to launch the Connector (Fig. 87). Choose **Next>** to continue.
14. For information on the Connector steps, please see 2.4. *Complete the 5big Backup Server Setup*.

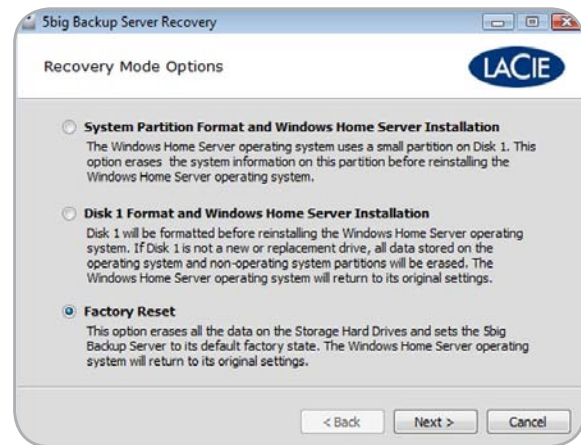

Fig. 85

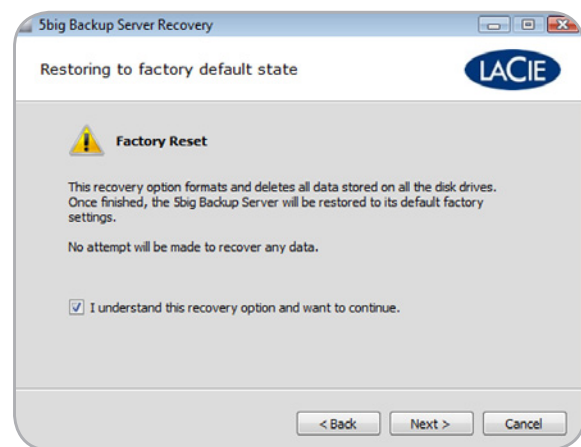

Fig. 86

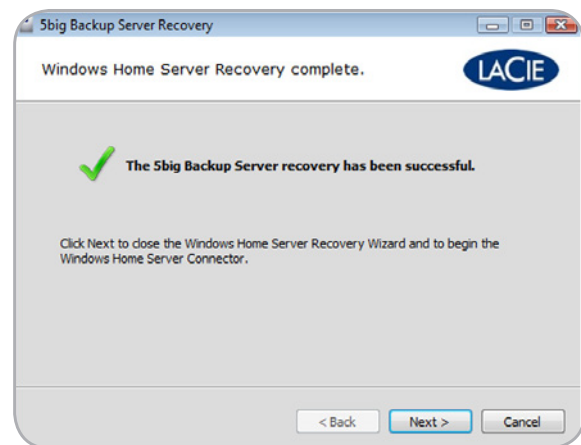

Fig. 87



## 7.2. Recovery: Workstations on the 5big Backup Server Network

The 5big Backup Server performs regular backups of all the Windows workstations that have been added to the **Console**. The benefits are apparent when preparing for worst-case scenarios. A user can retrieve files and folders that were mistakenly deleted and an administrator can restore the operating system and data on a computer that is experiencing errors.

Please consider the following before starting a recovery:

- ◆ PC recovery is compatible with Windows-based workstations only.
- ◆ The workstation must be on the same network as the 5big Backup Server.
- ◆ The workstation must have at least one backup on the 5big Backup Server.
- ◆ The drivers for the computer being recovered are backed up onto an external disk (7.2.1. [Workstation Drivers and File Recovery](#)).
- ◆ The PC Recovery CD is available to boot the Windows-based workstation.
- ◆ If the workstation does not have an optical disk drive, a bootable USB 2.0 recovery key must be available (see 7.2.2. [PC Recovery USB 2.0 Flash Drive \(Optional\)](#)).

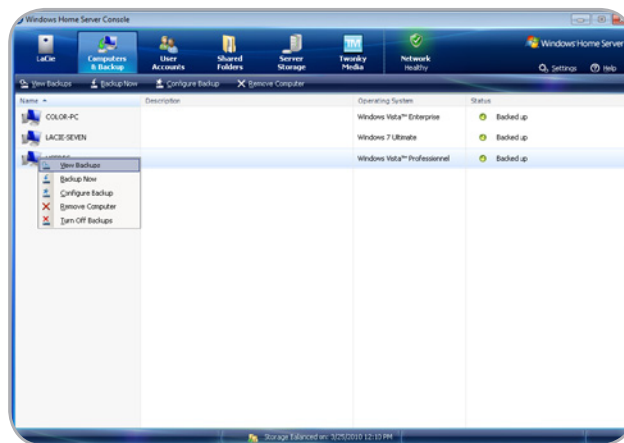

Fig. 88

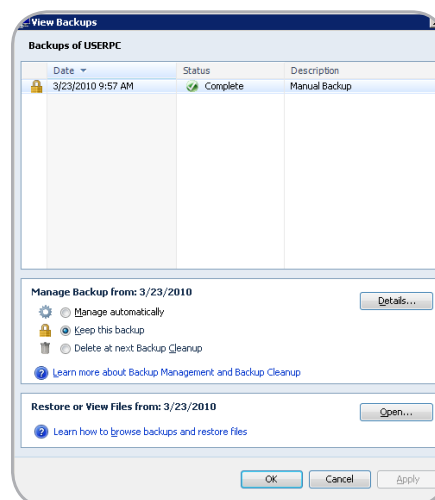

Fig. 89

### 7.2.1. Workstation Drivers and File Recovery Drivers

While the 5big Backup Server provides a complete backup of all the systems on the network, the recovery may not be able to install all the drivers. For this reason, Windows Home Server places certain drivers in a special folder called **Windows Home Server Drivers for Restore**.

To find the folder:

1. Select **Console > Computer & Backup**.
2. Make certain that the 5big Backup Server is not backing up other computers on the network.
3. Right-click on the computer that you will be recovering and choose **View Backups** (Fig. 88). (Even if the computer is not active and its image is grey, you may still access the backups).
4. On the bottom pane, **Restore or View Files from: xx/xx/xxxx**, click **Open...** (Fig. 89)
5. Select **Yes** at the next prompt regarding changes (Fig. 90).

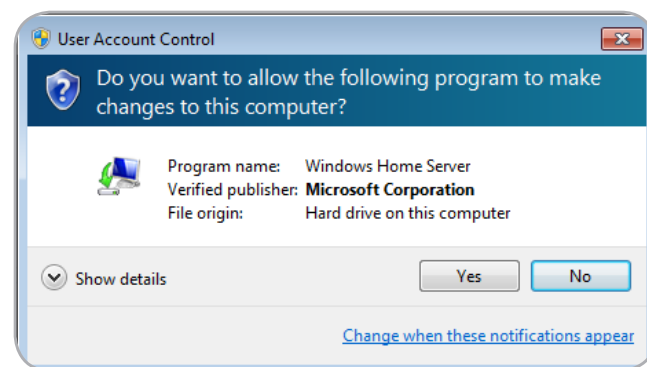

Fig. 90

continued on the next page >>

6. The Backup for the workstation will start to open (Fig. 91).
7. From the list of folders, copy **Windows Home Server Drivers for Restore** to an external disk or USB 2.0 flash drive in preparation for the computer recovery (Fig. 92).

---

**IMPORTANT INFO:** Drivers that come from a 64-bit system will not work with the included 32-bit PC Recovery CD. Clients must have 32-bit versions of the drivers for the recovery.

---

---

**IMPORTANT INFO:** When performing a PC recovery, Windows Home Server may experience minor problems with certain drivers used in Windows XP (32- or 64-bit). Please substitute drivers from Windows Vista (32-bit) or Windows 7 (32-bit) to compensate.

---

### Files

Once a Backup has opened (see the steps listed for **Drivers**), you may search for previous versions of files from the list of folders. Copy and paste the file(s) you wish to restore.

---

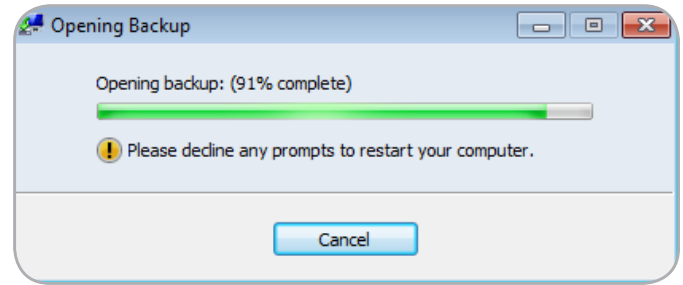

Fig. 91

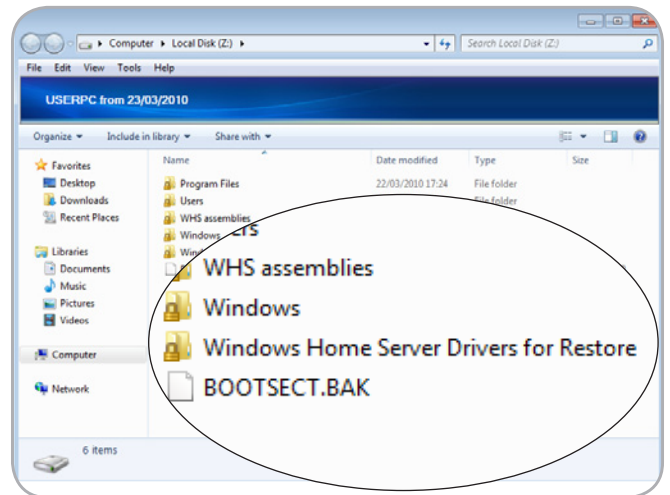

Fig. 92

### 7.2.2. PC Recovery USB 2.0 Flash Drive (Optional)

The included PC Recovery CD is a bootable disk that should be used when recovering a Windows workstation. However, some workstations may not have optical disk drives (i.e. netbooks). In such cases, you may create a PC recovery USB 2.0 flash drive.

1. Insert the PC Recovery CD into a workstation with an optical disk drive.
2. Insert a USB 2.0 flash drive into an available USB 2.0 port on the same workstation.

---

**IMPORTANT INFO:** Creating a PC recovery USB 2.0 flash drive will erase any data that is stored on the USB 2.0 flash drive. Please backup data that you want to preserve before moving to the next step.

---

3. Launch PC Recovery Key (PC Recovery CD>Applications>PC Recovery Key).
4. Please note the information on the welcome window (Fig. 93). Click **Next>** to continue.
5. Select the USB flash drive from the pulldown menu (Fig. 94). If there are more than one USB flash drives connected to your workstation, make certain to choose the target flash drive. Choosing the incorrect flash drive may delete data that you want to keep. Consider closing PC Recovery Key and removing all USB flash drives. Reinsert only the USB flash drive that you want to use as a server recovery disk.
6. Once the flash drive has been chosen, PC Recovery Key offers a green check mark indicating that the device is compatible (Fig. 95). If the flash drive is not compatible, a red "X" will appear.

---

**IMPORTANT INFO:** There are a great number of USB 2.0 flash drives manufactured by a wide range of companies. While many USB 2.0 flash drives from 512 MB to 4 GB should work as a recovery flash drive, LaCie cannot test every model. If PC Recovery Key experiences problems in creating the system recovery USB 2.0 flash drive, please try a different flash drive.

---

7. Click **Create Key>** to continue.

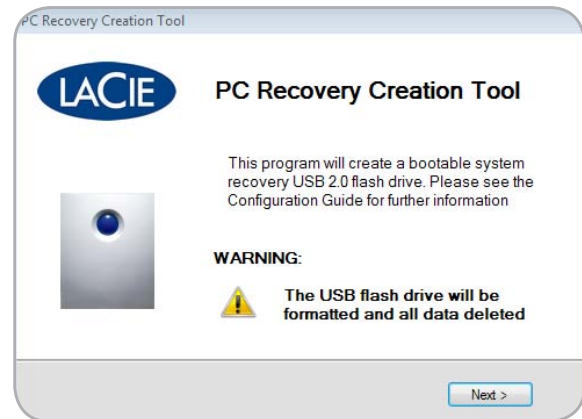

Fig. 93

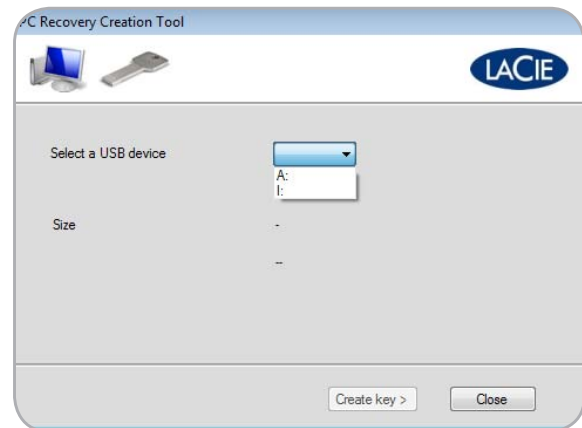

Fig. 94

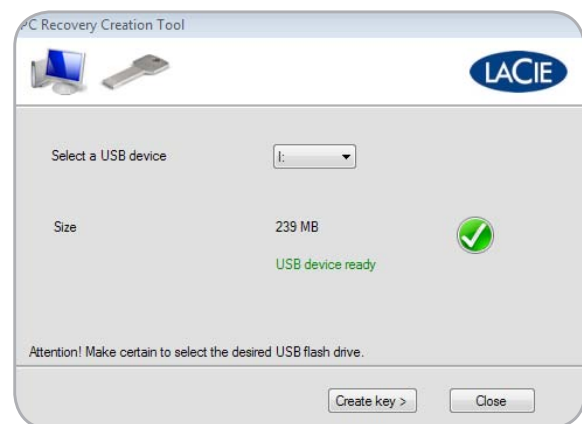

Fig. 95

continued on the next page >>

8. A prompt will warn you that creating a USB recovery key will delete all data on the flash drive. Click **OK** to continue (Fig. 96).
9. It will take a few minutes to create the recovery key. Once finished, click **OK** and safely eject the USB flash drive (Fig. 97).

---

**IMPORTANT INFO:** Please note that the PC recovery USB 2.0 flash drive is meant for Windows workstations only and should not be used to boot the 5big Backup Server in recovery mode.

---

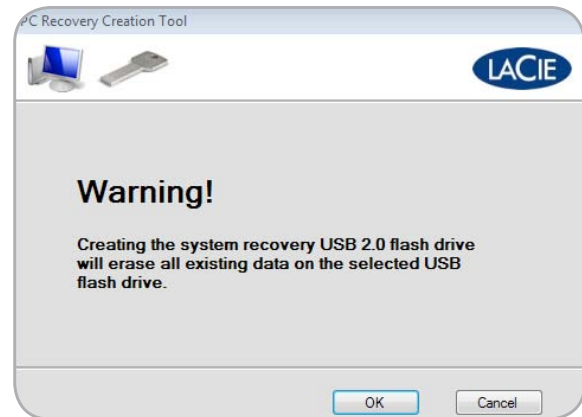

Fig. 96

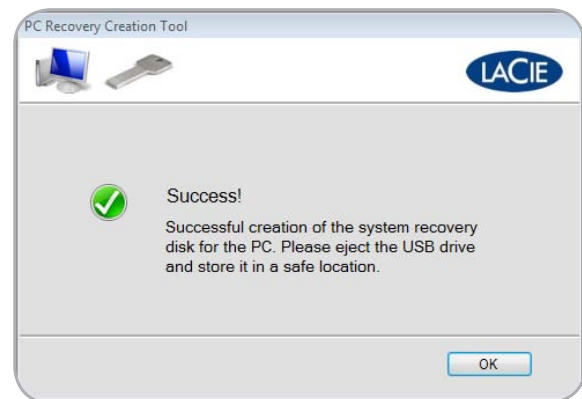

Fig. 97

### 7.2.3. PC Recovery (Windows Workstations Only)

**IMPORTANT INFO:** The 5big Backup Server must have at least one backup of the workstation being recovered. The recovery operation cannot succeed if the workstation has not been backed up by the 5big Backup Server.

In the event of workstation error or failure, the 5big Backup Server can help you restore the system to a previous, working state. Before starting a Windows recovery, it is highly recommended that you have all the tools at your disposal:

- ◆ The PC Recovery CD (included) or a PC Recovery USB 2.0 flash drive (7.2.2. *PC Recovery USB 2.0 Flash Drive (Optional)*)
  - ◆ The workstation drivers stored on the 5big Backup Server. The drivers should be copied to a USB 2.0 flash drive. See 7.2.1. *Workstation Drivers and File Recovery*
1. Make certain that the computer being recovered is connected to the same network as the 5big Backup Server.
  2. Insert the PC Recovery CD into your workstation’s optical disk drive. The workstation must boot from the CD. If the workstation being recovered does not include an optical disk drive, use a PC recovery USB 2.0 flash drive. See 7.2.2. *PC Recovery USB 2.0 Flash Drive (Optional)*.
  3. Once the computer starts from the CD or USB 2.0 flash drive, the recovery program will lead you through each step (Fig. 98).
  4. Choose your country and keyboard (Fig. 99). Click **Continue**.
  5. If the **Detect Hardware** window includes one or more network devices, click **Continue** and skip to step 13. (Fig. 100)

continued on the next page >>

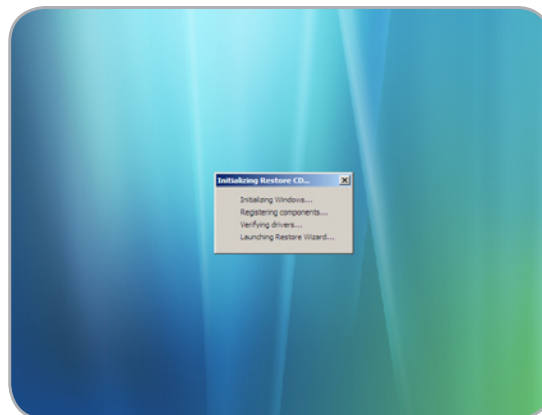

Fig. 98

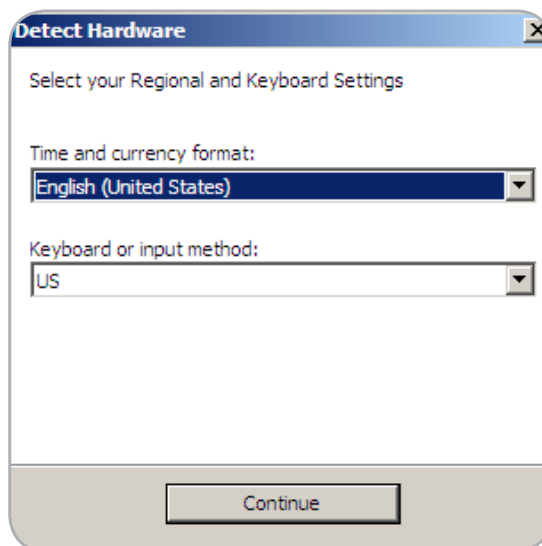

Fig. 99



Fig. 100

6. If the **Detect Hardware** window does not include a Network device (Fig. 101), click **Show Details...**
7. A new window opens to begin the installation of drivers. The drivers should be backed up on a USB 2.0 flash drive. See [7.2.1. Workstation Drivers and File Recovery](#) for information on how to store the drivers for a workstation that has been backed up by the 5big Backup Server. Please note that the drivers for the workstation being restored can be saved onto a USB 2.0 flash drive from another Windows workstation connected to the 5big Backup Server.
8. Click **Install Drivers...** (Fig. 102)

[continued on the next page >>](#)



Fig. 101

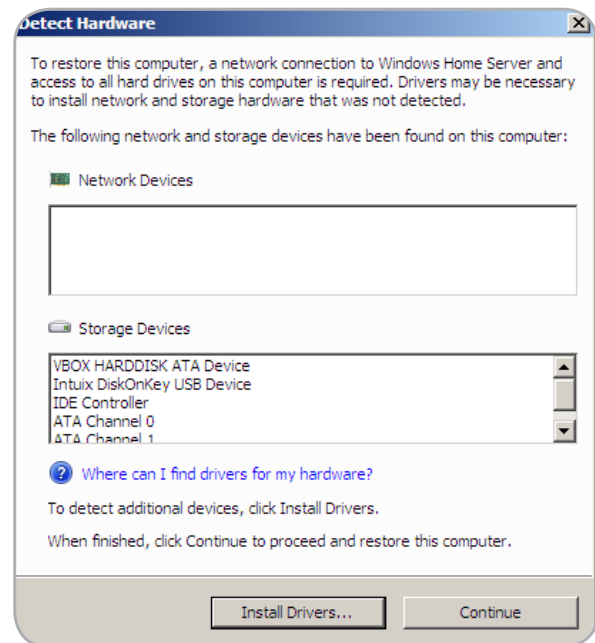

Fig. 102

9. Insert the USB 2.0 flash drive into a free USB 2.0 port (Fig. 103).  
Click **Scan**.

10. The recovery will load the drivers (Fig. 104). Click **OK**.

continued on the next page >>

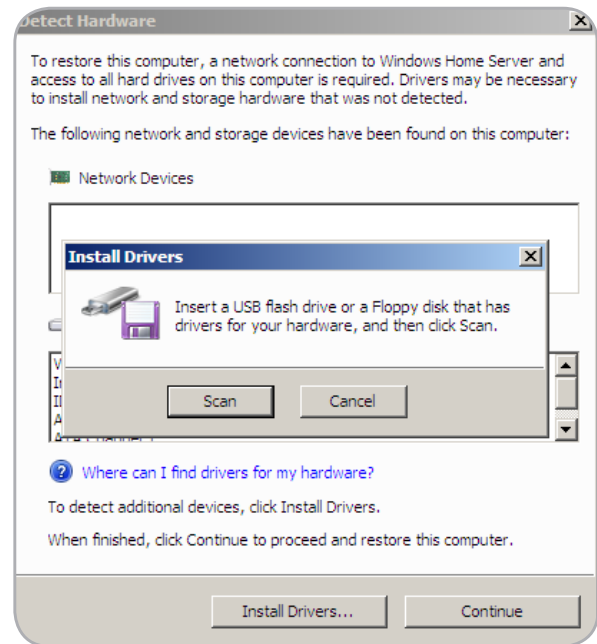

Fig. 103

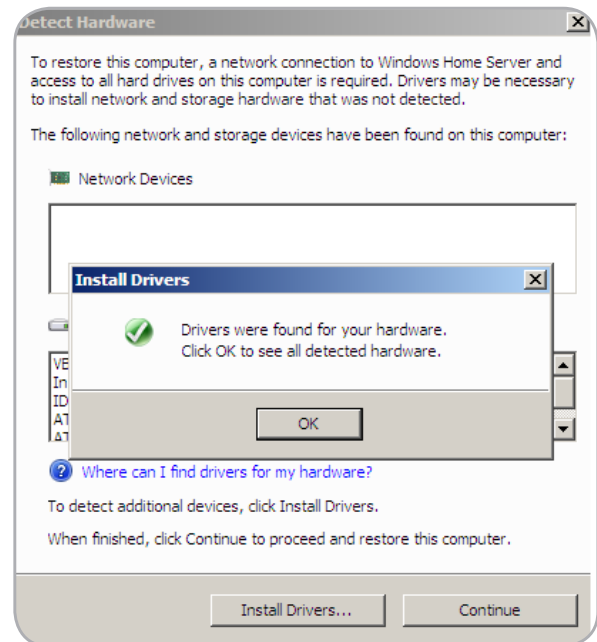

Fig. 104



11. Note that the recovery has installed the network driver, which is critical to communicating with the 5big Backup Server (Fig. 105) and launching the Restore Computer Wizard.
12. Click **Continue** (Fig. 105).
13. Read the welcome page carefully and select **Next>** (Fig. 106).

continued on the next page >>

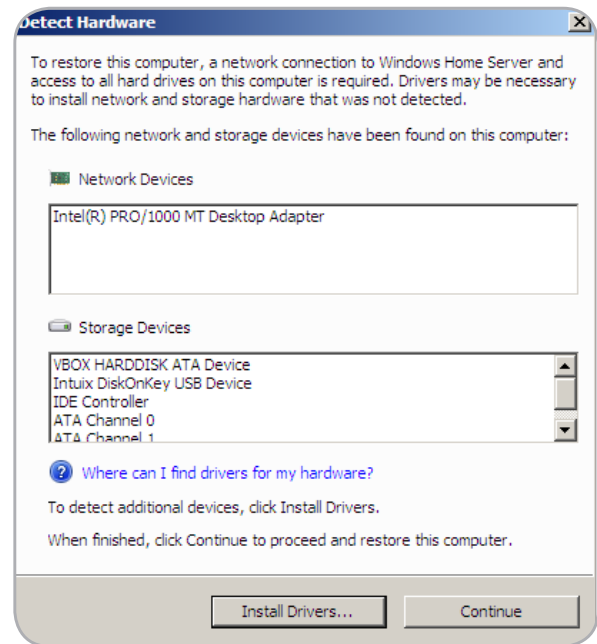

Fig. 105



Fig. 106

14. Enter the Administrator password for the 5big Backup Server (Fig. 107). Click **Next>**
15. Select the computer you wish to recover (Fig. 108). Click **Next>**.
16. Choose the backup you wish to restore to the workstation (Fig. 109).

[continued on the next page>>](#)



Fig. 107

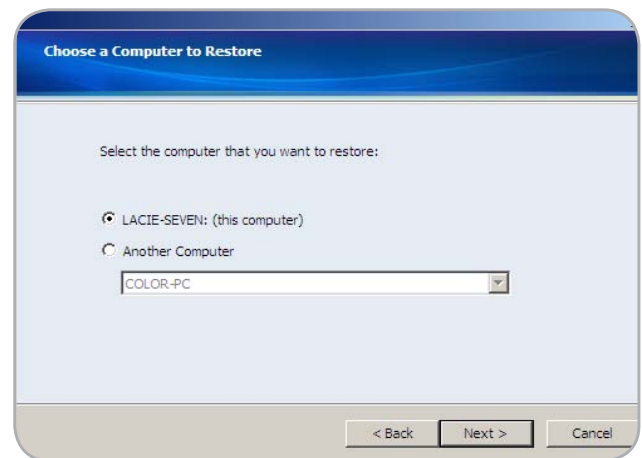

Fig. 108

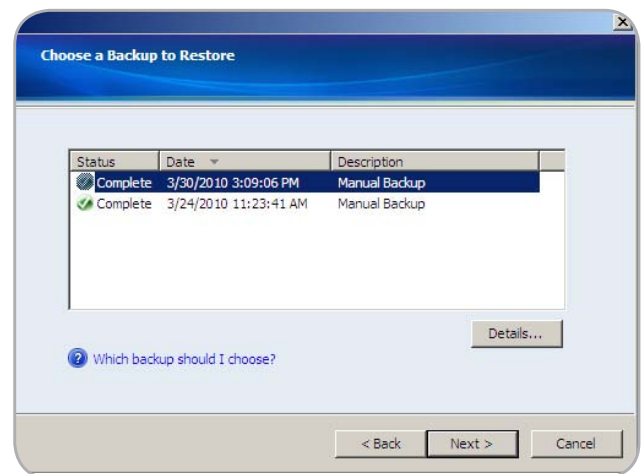

Fig. 109

17. Choose the volumes to restore (Fig. 110). Click **Next>**.
18. Confirm the volumes that you have chosen to restore (Fig. 111). Click **Next>**.
19. Please be patient while the 5big Backup Server restores the workstation. Depending upon the amount of data, restoring volumes may take quite some time (Fig. 112).

continued on the next page >>

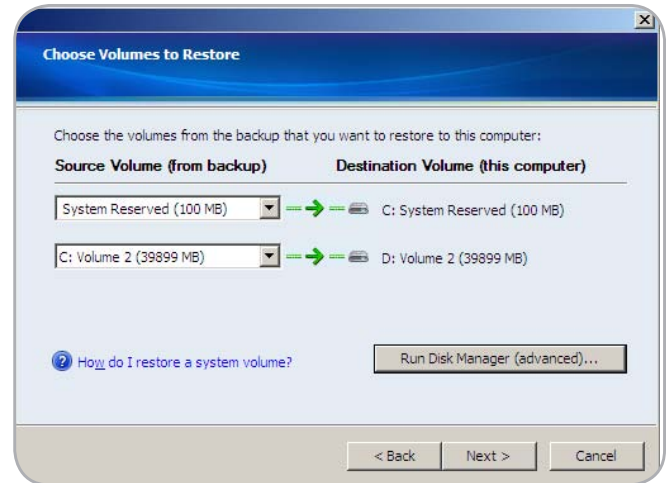

Fig. 110

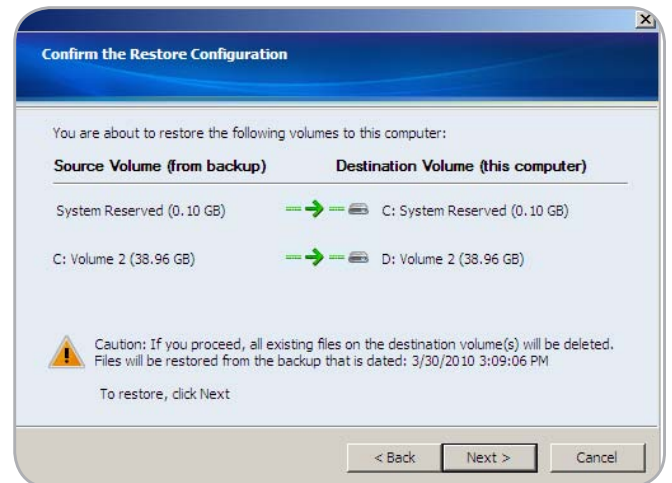

Fig. 111

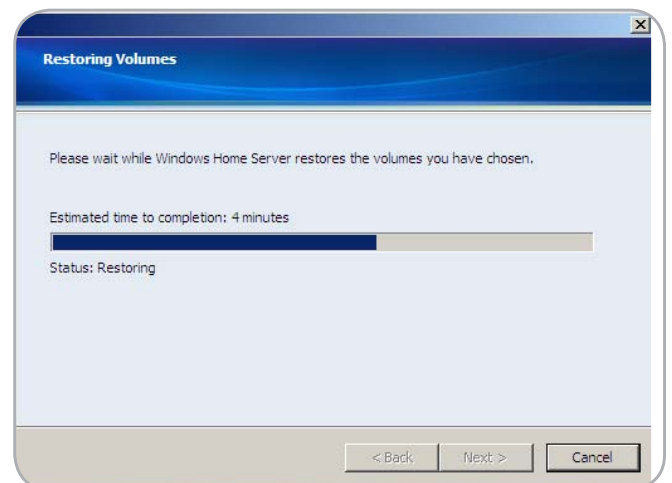

Fig. 112

20. When the volumes have been restored (Fig. 113), click **Finish**.
21. The computer will restart. Upon reboot, you will have the option to start Windows in Normal mode or Safe mode.

---

**IMPORTANT INFO:** As with most recovery operations, LaCie cannot guarantee that all files and settings will be restored.

---

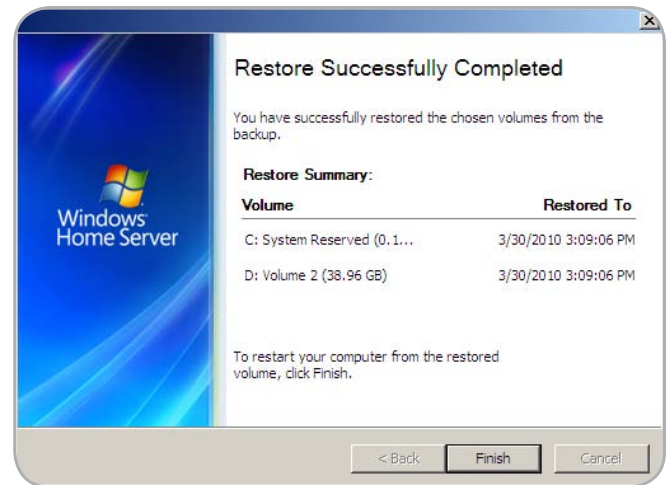















Fig. 113

## 8. LED Indicators

The LED indicators above the drive bays and the front LED indicate drive status and activity. This section describes the behavior of the LED indicators.

Front LED Color	Rear LED Colors	5big Backup Server State
Solid blue 	Blinking blue 	<ul style="list-style-type: none"> <li>◆ Disk(s) not added to Storage Hard Drives</li> <li>◆ Server has not been configured</li> </ul>
Solid blue 	Solid blue 	Disk(s) added to Storage Hard Drive(s)
Rapid blinking blue 	Solid blue 	Occurs as the 5big Backup Server is booting. The blinking will cease once the 5big Backup Server is fully initialized.
Solid red 	Solid blue  and/or Solid red 	Hardware failure or Disk 1 (Windows Home Server operating system) is non-functional or missing. Make certain the disk is inserted properly and reboot the system. Contact Technical Support if the problem persists.
Solid blue 	Solid red 	One or more disk(s) failure. Files may be lost if they were not duplicated (see <a href="#">3.2. Shared Folders</a> ).
Solid blue 	LED has no activity or unlit	The 5big Backup Server does not recognize the disk. Make certain the disk is inserted properly. If the problem continues, replace it with another drive.
Blinking blue 	Solid blue 	5big Backup Server is booting in Recovery mode from a USB drive.

## 9. Troubleshooting

In the event that your LaCie 5big Backup Server is not working correctly, please take a look at the Troubleshooting section on the following pages and at the FAQs published on our web site – [www.lacie.com](http://www.lacie.com). One of these FAQs may provide an answer to your specific question. You can also visit the downloads page, where the most recent software updates will be available:

[www.lacie.com/support/downloads](http://www.lacie.com/support/downloads).

If you need further assistance, please contact your LaCie reseller or LaCie Technical Support (see chapter [10. Contacting Customer Support](#) for details).

### Manual Updates

LaCie strives to give you the most up-to-date, comprehensive guides possible. It is our goal to provide you with a friendly, easy-to-use format that will help you quickly install and utilize the many functions of your device.

If your guide does not reflect the configurations of the product that you purchased, please check our web site for the most current version available: [www.lacie.com](http://www.lacie.com)

For the latest information about Windows Home Server, see “Release Documentation for Windows Home Server” at the Microsoft Web site: <http://go.microsoft.com/fwlink/?LinkID=84725>.

[continued on the next page>>](#)

Problem	Question	Solution
The system is not recognized by the computer.	Does your computer's configuration meet the minimum system requirements?	Check section <a href="#">1.3. Minimum Workstation Operating System Requirements</a> for more information.
	Is the system's power supply connected and is the blue light on the front of the drive on?	Make sure: <ul style="list-style-type: none"> <li>◆ That the power supply is properly connected (see section <a href="#">2.1. Turning On the 5big Backup Server</a> for details).</li> <li>◆ That the system has been powered on by pushing the LED button on the front of the device.</li> <li>◆ That the electrical outlet hosting the 5big Backup Server power supply has a sufficient supply of power.</li> </ul>
	Is the blue light on the front of the device flickering?	If the blue LED on the face of the 5big Backup Server is flickering or will not turn on, the power supply may be defective. Please contact your LaCie reseller or LaCie Customer Support.
	Did you follow the correct installation steps?	<b>5big Backup Server</b> - Review the installation steps ( <a href="#">2.2. Connecting the Ethernet Cable</a> ).  <b>Workstation</b> - Connect your workstation the network (using either a wired or a wireless connection), and make sure the workstation is on the same logical network as 5big Backup Server.
	Are both ends of the Ethernet cable firmly connected?	<ul style="list-style-type: none"> <li>◆ Disconnect the Ethernet cable on both ends, wait 10 seconds and then reconnect.</li> <li>◆ Ensure that the interface connectors are properly aligned and the Ethernet cable correctly oriented.</li> <li>◆ Check that the Ethernet connectors are straight and fully seated in the Ethernet ports.</li> <li>◆ Make sure that you use the Ethernet cord provided in the 5big Backup Server box.</li> </ul>
The system does not appear on the network.	Is your network DHCP enabled?	The 5big Backup Server is compatible with a network that includes a DHCP server.
A user does not have access to the LaCie 5big Backup Server.	Has the administrator created an account for the user?	In order for a user to access the LaCie 5big Backup Server, two conditions must be met: <ol style="list-style-type: none"> <li>1) the administrator must create and register the user with the appropriate privileges;</li> <li>2) the LaCie 5big Backup Server must be connected to the same network via Ethernet.</li> </ol>



Problem	Question	Solution
There seems to be a conflict.	Have you changed the parameters of your firewall or anti-virus programs?	Make sure firewall software on your workstation is not blocking access to the 5big Backup Server.
My computer from work will not connect to the 5big Backup Server.	Do you have administration rights to your work computer?	If your computer has been joined to a corporate network (such as a laptop you use at work), check with the corporate network administrator about the IPsec policy. This may block access from the corporate computer to the 5big Backup Server.
Windows Home Server only recognizes a part of my non-LaCie storage.	I just bought a new 3TB drive and added it to the Storage Hard Drives. Why is Windows Home Server only using 2TB of the drive?	Windows Home Server cannot add more than 2TB of a single disk to its pool of Storage Hard Drives. For example, if you add a 3TB non-LaCie drive into the pool of Storage Hard Drives, Windows Home Server will only use 2TB of its capacity. The remaining storage will be placed in the System as unavailable.
Folder Duplication does not work.	Why is Folder Duplication unavailable?	You must have more than one disk in the pool of Storage Hard Drives to enable Folder Duplication.
Folder Duplication must be enabled manually.	I now have more than one drive in the Windows Home Server pool of Storage Hard Drives. Why is Folder Duplication still disabled on my older folders? The Configuration Guide says that Folder Duplication is enabled by default ( <a href="#">3.2.1. Folder and File Duplication</a> ).	You may have run the Connector CD with only one hard drive in the 5big enclosure. In this case, all of the default Windows Home Server folders as well as folders created by users could not enable Folder Duplication. Once additional disks are added to the Windows Home Server pool of Storage Hard Drives, Folder Duplication may be enabled manually. In addition, Folder Duplication will be enabled by default for new folders created by users.

## 10. Contacting Customer Support

### Before You Contact Technical Support

Read the User Manual and review the Troubleshooting section.

Try to isolate the problem. If possible, make the 5big Backup Server the only storage device on the network, and confirm that all of the cables are correctly and firmly attached.

If you have asked yourself all of the pertinent questions in the troubleshooting checklist, and you still can't get your LaCie 5big Backup Server to work properly, contact us via the contacts on the following page. Before contacting us, make sure that you are in front of your computer and that you have the following information on hand:

Information	Where to Find Information
LaCie 5big Backup Server serial number	Located on a sticker at the back of drive or on the original packaging
PC model	Right click <b>My Computer</b> and select <b>Properties &gt; General</b> .
Operating system version	
Processor speed	
Computer memory	
The brands and models of other internal and external peripherals installed on my computer	Right click <b>My Computer</b> and select <b>Properties &gt; Hardware</b> .

## 10.1. LaCie Technical Support Contacts

<p>LaCie Asia <a href="http://www.lacie.com/cn/contact/">http://www.lacie.com/cn/contact/</a></p>	<p>LaCie Australia <a href="http://www.lacie.com/au/contact/">http://www.lacie.com/au/contact/</a></p>
<p>LaCie Belgium <a href="http://www.lacie.com/be/contact/">http://www.lacie.com/be/contact/</a> (Dutch) <a href="http://www.lacie.com/befr/contact/">http://www.lacie.com/befr/contact/</a> (French)</p>	<p>LaCie Brazil <a href="http://www.lacie.com/us/contact/">http://www.lacie.com/us/contact</a></p>
<p>LaCie Canada <a href="http://www.lacie.com/ca/contact/">http://www.lacie.com/ca/contact/</a> (English) <a href="http://www.lacie.com/cafr/contact/">http://www.lacie.com/cafr/contact/</a> (French)</p>	<p>LaCie Denmark <a href="http://www.lacie.com/dk/contact/">http://www.lacie.com/dk/contact</a></p>
<p>LaCie Finland <a href="http://www.lacie.com/fi/contact/">http://www.lacie.com/fi/contact/</a></p>	<p>LaCie France <a href="http://www.lacie.com/fr/contact/">http://www.lacie.com/fr/contact/</a></p>
<p>LaCie Germany <a href="http://www.lacie.com/de/contact/">http://www.lacie.com/de/contact/</a></p>	<p>LaCie Ireland <a href="http://www.lacie.com/ie/contact/">http://www.lacie.com/ie/contact/</a></p>
<p>LaCie Italy <a href="http://www.lacie.com/it/contact/">http://www.lacie.com/it/contact/</a></p>	<p>Japan - Elecom CO., LTD <a href="http://www.lacie.com/jp/contact/">http://www.lacie.com/jp/contact/</a></p>
<p>LaCie Korea <a href="http://www.lacie.com/kr/contact/">http://www.lacie.com/kr/contact</a></p>	<p>LaCie Latin America <a href="http://www.lacie.com/la/contact/">http://www.lacie.com/la/contact/</a></p>
<p>LaCie Netherlands <a href="http://www.lacie.com/nl/contact/">http://www.lacie.com/nl/contact/</a></p>	<p>LaCie Norway <a href="http://www.lacie.com/no/contact/">http://www.lacie.com/no/contact/</a></p>
<p>LaCie Portugal <a href="http://www.lacie.com/pt/contact/">http://www.lacie.com/pt/contact/</a></p>	<p>LaCie Singapore <a href="http://www.lacie.com/asia/contact/">http://www.lacie.com/asia/contact/</a></p>
<p>LaCie Southeast Asia <a href="http://www.lacie.com/sea/contact/">http://www.lacie.com/sea/contact</a></p>	<p>LaCie Spain <a href="http://www.lacie.com/es/contact/">http://www.lacie.com/es/contact/</a></p>
<p>LaCie Sweden <a href="http://www.lacie.com/se/contact/">http://www.lacie.com/se/contact</a></p>	<p>LaCie Switzerland <a href="http://www.lacie.com/ch/contact/">http://www.lacie.com/ch/contact</a> (German) <a href="http://www.lacie.com/chfr/contact/">http://www.lacie.com/chfr/contact/</a> (French) <a href="http://www.lacie.com/chit/contact/">http://www.lacie.com/chit/contact/</a> (Italian)</p>
<p>LaCie UK <a href="http://www.lacie.com/uk/contact/">http://www.lacie.com/uk/contact</a></p>	<p>LaCie USA <a href="http://www.lacie.com/us/contact/">http://www.lacie.com/us/contact/</a> (English) <a href="http://www.lacie.com/uses/contact/">http://www.lacie.com/uses/contact</a> (Spanish)</p>
<p>LaCie Grand Export <a href="http://www.lacie.com/intl/contact/">http://www.lacie.com/intl/contact/</a></p>	

## 11. Warranty Information

LaCie warrants your drive against any defect in material and workmanship, under normal use, for the period designated on your warranty certificate. In the event this product is found to be defective within the warranty period, LaCie will, at its option, repair or replace the defective drive. This warranty is void if:

- ◆ The drive was operated/stored in abnormal use or maintenance conditions;
- ◆ The drive is repaired, modified or altered, unless such repair, modification or alteration is expressly authorized in writing by LaCie;
- ◆ The drive was subjected to abuse, neglect, lightning strike, electrical fault, improper packaging or accident;
- ◆ The drive was installed improperly;
- ◆ The serial number of the drive is defaced or missing;
- ◆ The broken part is a replacement part such as a pickup tray, etc.
- ◆ The tamper seal on the drive casing is broken.

LaCie and its suppliers accept no liability for any loss of data during the use of this device, or for any of the problems caused as a result.

LaCie will not, under any circumstances, be liable for direct, special or consequential damages such as, but not limited to, damage or loss of property or equipment, loss of profits or revenues, cost of replacement goods, or expense or inconvenience caused by service interruptions.

Any loss, corruption or destruction of data while using a LaCie drive is the sole responsibility of the user, and under no circumstances will LaCie be held liable for the recovery or restoration of this data.

Under no circumstances will any person be entitled to any sum greater than the purchase price paid for the drive.

To obtain warranty service, call LaCie Technical Support. You will be asked to provide your LaCie product's serial number, and you may be asked to furnish proof of purchase to confirm that the drive is still under warranty.

All drives returned to LaCie must be securely packaged in their original box and shipped with postage prepaid.

### Note to Australian Customers

Our goods come with guarantees that cannot be excluded under the Australian Consumer Law. You are entitled to a replacement or refund for a major failure and for compensation for any other reasonably foreseeable loss or damage. You are also entitled to have the goods repaired or replaced if the goods fail to be of acceptable quality and the failure does not amount to a major failure.

#### Contact us:

LaCie Australia, 458 Gardeners Road Alexandria, NSW 2015 AUSTRALIA.

Phone: 02 8063 3711

Email: [info.au@lacie.com](mailto:info.au@lacie.com)

For fast technical support, create a support ticket after registering your product at <http://www.lacie.com/au/register>.

---

**IMPORTANT INFO:** Register online for free technical support: [www.lacie.com/register](http://www.lacie.com/register)

---